

A large, leafy tree dominates the left side of the image. Under its shade, a group of people, mostly men, are sitting on the ground in a circle, engaged in a meeting or conference. The background shows a rural landscape with more trees and a clear sky. The image is overlaid with horizontal bands of color: red at the top, followed by yellow, green, and blue.

# A Manifesto for CLIMATE RESPONSIVE DESIGN

Proceedings of a conference on raising awareness of  
Climate Responsive Design in East Africa  
27<sup>th</sup> - 28<sup>th</sup> February 2019

Peter Clegg and Isabel Sandeman of Feilden Clegg Bradley Studios on behalf of Enabel

FeildenCleggBradleyStudios

Enabel



Belgium  
partner in development

## PREFACE

Although countries in East-Africa seem to have a perfect climate, people are not fully benefiting or making efficient use of its potential. They suffer from insufficient daylight or overheating and live on sites that are not coherently organized nor efficiently utilised. Energy is wasted. Trees are considered an abundant energy provider, especially for cooking purposes or for burning bricks.

The Forum on 'Raising Awareness for Climate Responsive Design in East Africa' took place in Kampala (Uganda) on 27<sup>th</sup> and 28<sup>th</sup> February 2019. It was organized by Enabel, the Belgian development agency, and the Construction Management Unit of the Ministry of Education and Sports. Enabel (until 2018 called 'BTC' or Belgian Technical Cooperation) has been active in Uganda since 2005 mainly in the Education and Healthcare sectors.

Architects and engineers must learn to identify the constraints and opportunities of each project site and help local communities to develop their full potential. We hope this document will achieve the critical mass necessary to instigate lasting behavioural change in the way we are living in our environment.

The group of organizers and speakers at the Forum decided to sustain momentum and set up a platform that would bring together a community

Jan Van Lint  
Enabel



# A Manifesto for CLIMATE RESPONSIVE DESIGN

Proceedings of a conference on raising awareness of  
Climate Responsive Design in East Africa  
27<sup>th</sup> - 28<sup>th</sup> February 2019

Peter Clegg and Isabel Sandeman of Feilden Clegg Bradley Studios on behalf of Enabel

FeildenCleggBradleyStudios Enabel   Belgium  
partner in development

# INTRODUCTION

The Earth is facing twin challenges of climate change and biodiversity loss. The impact of these interlinked crises will vary across different parts of the world, but will affect the way in which we develop our built environment.

This publication looks at the future direction of architecture in East Africa and how it will respond to the environmental crises we face. As such this guide is aimed towards the particular climate and cultural context of East Africa, referring to case study examples from Uganda, Rwanda, the DRC and Malawi. The principles of the Manifesto, however, can be interpreted and applied to different contexts and climate zones globally.

The document has evolved from a conference run by Enabel in February 2019 which brought together expertise from across East Africa to raise awareness of climate responsive design. The conference and therefore this document, focusses predominantly on single storey community buildings in rural areas, however we recognise that considering the rapid urbanisation in East Africa, climate responsive design thinking will need to be extended to higher-density, higher-rise buildings in the future.

The guide is organised into five sections. The first section is a concise introduction to the issues surrounding climate and CLIMATE CHANGE on a global and regional scale.

The second section looks at the PARTICIPATORY PROCESS of developing buildings to serve communities, which needs to start with the communities themselves. Sustainable development needs to be owned and respected.

The third section deals with the choice of SUSTAINABLE MATERIALS used in building processes. The environmental impacts of various materials are explored from construction through to reuse. The choice of materials is based on what is available locally and economically.

The fourth section deals with BIOCLIMATIC DESIGN. This looks at the way the detailed design of buildings can create comfortable internal environments using solar energy and natural ventilation. The principles include water and sanitation, daylight and ventilation, and the use of renewable energy systems.

Finally, we look at a series of CASE STUDIES which gives examples of how the aforementioned sustainable design principles have been applied in practice. The principles are colour coded and linked to specific aspects of each exemplar design. These projects represent a new generation of architecture, which illustrates a developing understanding of how the built environment can help mitigate the impact of climate change and biodiversity loss.

## 1. Climate Change

- » Global Concerns
- » The Regional Context
- » The Climate of Uganda

## 2. Participatory Process

- » Participatory Design
- » Participatory Construction

## 3. Sustainable Materials

- » Material Considerations
- » Floors and Foundations
- » Wall Materials
- » Window Openings
- » Roof Structure and Covering
- » Material Innovation

## 4. Bioclimatic Design

- » Solar Shading
- » Passive Ventilation
- » Natural Daylight
- » Sustainable Landscape
- » Energy Generation
- » Water Management
- » Water Storage
- » Waste Management
- » Human Waste

## 5. Case studies

- 1 COF Outreach Village Schools – Studio FH
- 2 Rugerero Health Centre - ASA Studio
- 3 Ilima Primary School – MASS Design Group
- 4 National Teachers' College Kaliro – FBW Group
- 5 Lake Bunyonyi Secondary School – Feilden Foundation
- 6 ECD & F Centres - ASA Studio
- 7 Ruhehe Primary School – MASS Design Group
- 8 RLS Dormitory – ASA Studio
- 9 AWF Primary Schools – Studio FH
- 10 Mzuzu University Health Centre – Feilden Foundation
- 11 Nakapiripirit Vocational Institute - ProPlanPartners

# THE MANIFESTO

Universal principles of climate responsive design arising from experience in East Africa

## 1. Engage in a participatory design process

» Involve project stakeholders in every stage of the design and construction process for low-carbon, long-lasting buildings that effectively fulfil the needs of users.

## 2. Support local labour and develop local skills

» Leverage the construction process to build local capacity and provide training and work opportunities for the local community.

## 3. Grow or salvage local materials

» Use local materials with low embodied carbon, which are preferably grown or recycled such as responsibly sourced timber from managed plantations.

## 4. Design with the climate not against it

» Utilise passive ventilation strategies, natural daylighting and energy from the sun, but protect from solar overheating and glare.

## 5. Nurture the local ecosystem

» Biodiverse natural landscapes promote health and wellbeing, provide climatic cooling and mitigation against the effects of extreme weather events.

## 6. Produce clean on-site energy

» On-site renewable energy generation can cover or supplement energy requirements and help to offset embodied carbon in the building fabric.

## 7. Utilise sustainable water sources

» Recycle grey water and harvest and store rainwater for reuse on site, and to help prevent flooding and erosion.

## 8. Provide water, sanitation and hygiene facilities

» Ensure healthy disposal and recycling of human waste, as well as adequate hand washing facilities and clean filtered water for human consumption.

## 9. Share knowledge and experience

» Designers, builders and building users should work together to combat climate change and learn from successes and failures.

## 10. Avoid the pitfalls of the industrialised world

» Developing countries can leapfrog the industrialised world through constructing passive buildings and investing into clean energy and smart LZC technologies.

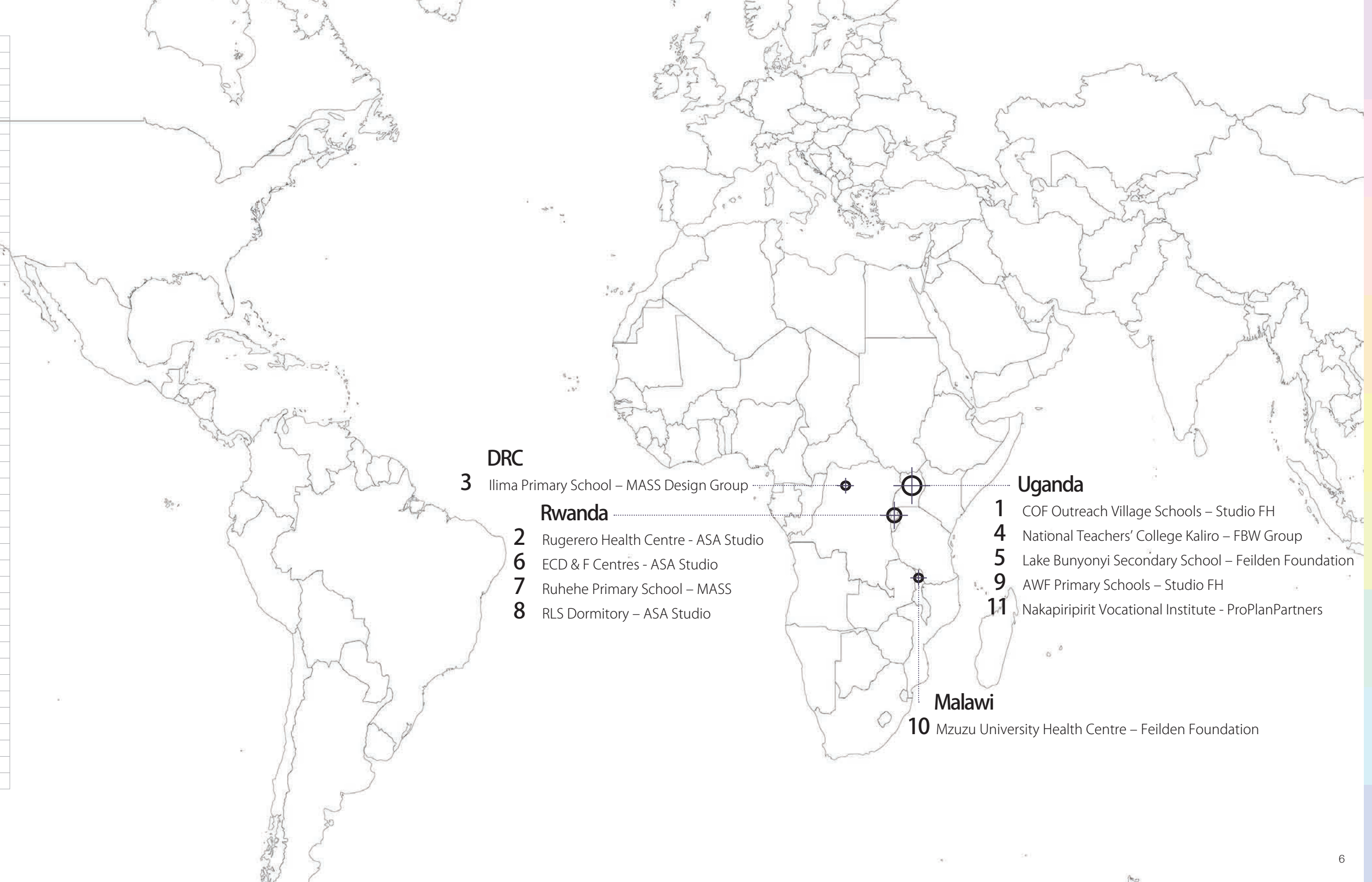

### DRC

3 Ilima Primary School – MASS Design Group

### Rwanda

2 Rugerero Health Centre - ASA Studio

6 ECD & F Centres - ASA Studio

7 Ruhehe Primary School – MASS

8 RLS Dormitory – ASA Studio

### Uganda

1 COF Outreach Village Schools – Studio FH

4 National Teachers' College Kaliro – FBW Group

5 Lake Bunyonyi Secondary School – Feilden Foundation

9 AWF Primary Schools – Studio FH

11 Nakapiripirit Vocational Institute - ProPlanPartners

### Malawi

10 Mzuzu University Health Centre – Feilden Foundation



1 CLIMATE CHANGE

# GLOBAL CONCERNS

The world is facing twin unprecedented challenges of global warming and biodiversity loss. According to the recent report by the UN Intergovernmental Panel on Climate Change (IPCC) we have only 12 years to change direction on greenhouse gas emissions before we reach a situation where global warming becomes irreversible. The Intergovernmental Science-Policy Platform on Biodiversity and Ecosystem Services (IPBES) has stated that we are currently in the midst of the sixth mass extinction on planet earth. The need to face up to these crises lies primarily with the industrialised countries of the world, but most of Africa will have to adopt policies of both adaptation and mitigation as they undergo a process of rapid urbanisation and economic growth. An holistic approach to sustainable building design is one way in which the worst consequences of these crises can be avoided.

For more information see:  
<https://regenesishgroup.com/>  
 Raworth, K. (2017). Doughnut economics : seven ways to think like a 21st-century economist, Random House Business.

## CLIMATE CHANGE

Any more than a 1.5C increase in average global temperatures will significantly worsen the risks of drought, flooding, extreme heat and poverty.

The landmark report by the IPCC released in October 2018 stated that urgent and unprecedented changes are needed to reach a target of no more than 1.5C increase in average global temperatures. They warned that any more than this amount could have catastrophic consequences for the planet, affecting hundreds of millions of people.

Much of this crisis is caused by extraordinarily high levels of greenhouse gas emissions from industrialised countries. It is difficult to blame East African countries for any part in this problem but as economies develop, CO2 emissions do tend to rise. There is a hope that development in East Africa could be disassociated from an increase in carbon emissions, and that East Africa could leapfrog the industrialised world by investing in and implementing sustainable policy from the onset.

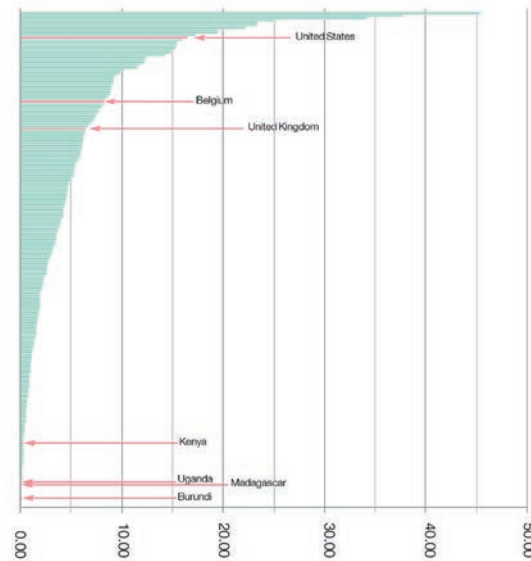

Comparative carbon emissions in tonnes of CO2 per capita for different countries around the world. Data source World Bank Open Data Portal.

## CARBON EMISSIONS

Buildings contribute approx. 40% of overall global CO2 emissions, both through their construction (embodied energy) and through energy in use (operational energy).

The construction of buildings means using materials which generate carbon dioxide during their production. The typical materials used to construct school buildings - concrete and fired clay bricks - both have relatively high embodied energy; the former because of the release of CO2 during the production of cement, and the latter because firing bricks is a significant driver of deforestation.

Buildings also usually require energy in operation, although in East Africa this requirement may be minimal. If the electricity used is generated from burning fossil fuels then there is a consequent carbon emission, while solar pv and other renewable energy technologies can be considered carbon neutral. Firewood used for cooking results in net carbon emissions unless it is sourced from a sustainably managed forest or plantation.

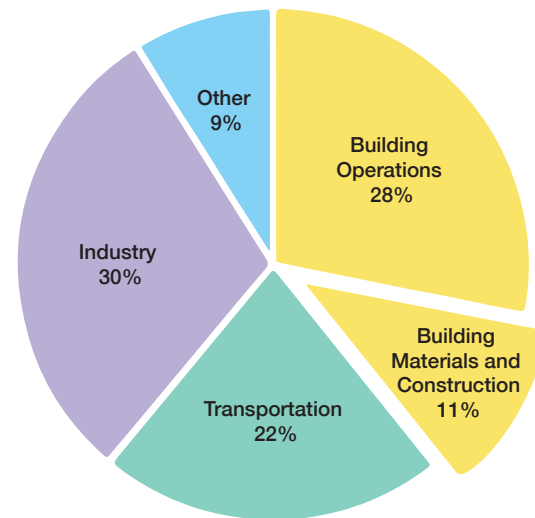

Global CO2 emissions by sector, showing that the building industry is the most significant contributor. Data source World Bank Open Data Portal.

## LOSS OF BIODIVERSITY

The accelerating loss of biodiversity has untold consequences for humanity: we are undermining the bedrock that enables our health and well-being.

It is generally acknowledged that the world is going through a potentially irreversible process of species loss, caused primarily by climate change, pollution and habitat loss. Reduced biodiversity leads to reduced ecosystem services that ultimately creates a danger for food security. The IPBES reported in May 2019 that there was a desperate need to conserve enough space for terrestrial and marine ecosystems to continue to function.

In many parts of East Africa, rapid population growth and demands for agricultural land are causing unprecedented levels of deforestation and habitat degradation. The loss of forest has been satellite monitored by Forest Watch for the last 20 years; if deforestation is translated into carbon emissions then per capita CO2 emissions in Uganda would almost double, while Madagascar's emissions would become comparable to many European countries.

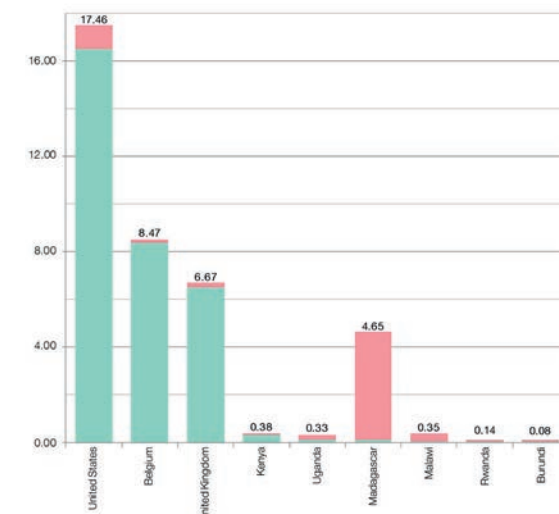

Comparative carbon emissions in tonnes of CO2 per capita including emissions from deforestation and habitat degradation. Data source World Bank Open Data Portal and Global Forest Watch.

## SUSTAINABLE DEVELOPMENT

Every person should have the resources they need to meet their human rights, while collectively we live within the ecological means of our planet.

Currently the world's population is hugely divided by social and economic inequality. At current population levels our planet can provide 1.6 global hectares (gha) of biologically productive surface area per person. Yet people in the USA have an ecological footprint of 8.1gha, compared to those in Uganda with 1.06gha and Rwanda with just 0.76gha. Rich countries are consuming resources on a vast scale and creating epic amounts of waste and pollution, while poorer countries suffer a lack of food, energy and resources.

In her book 'Doughnut Economics', Kate Raworth from Oxfam has developed an economic theory which places humanity's 21st century challenge as ensuring people's needs are met without overshooting the Earth's ecological limits. The 'doughnut' of planetary and social boundaries is an approach to framing that challenge, inspired by the social aims of the UN Sustainable Development Goals.



The safe space for humanity exists between the ceiling imposed by environmental limits and the social foundation ensuring basic human rights for all. Adapted Raworth, K. (2017). Doughnut economics

## REGENERATIVE DESIGN

The destruction of nature and the devastating consequences of climate change demand an alternative and holistic approach to design.

Regenerative design is an approach which seeks to go beyond minimal impact to the natural environment, and aims to develop restorative and equitable systems that create positive benefit for humans and other species. The focus is on building capacity through a radically particular and respectful design process. This is achieved through participatory design and the mutual development of people and place. A whole systems approach to design improves the way we manage and restore degraded ecosystems and can transform economic and business models, as well as consumption and production patterns. When building a school, it is important to consider the production of food and waste and ensure that these are dealt with on site as part of a natural circular economy. Resources such as rainwater and solar energy should be part of an holistic approach to the management of the site.

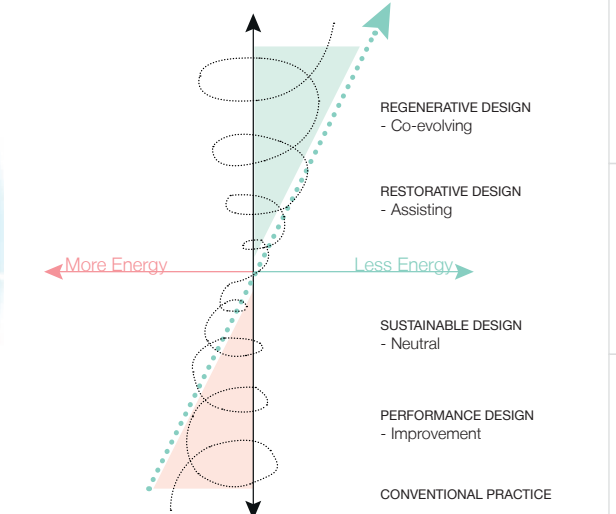

The trajectory of environmentally responsible design; from conventional to sustainable to regenerative systems. Adapted from Bill Reed 2007, Regenesish Group.

# REGIONAL CONCERNS

East Africa faces its own particular versions of the global challenges of climate change and biodiversity loss. Without the provision of suitable climate-ready buildings and infrastructure, global warming will quickly turn the region from being comfortable to being inhospitable. Furthermore, East Africa's high level of biodiversity and varied ecosystems means that the stakes are exceptionally high when it comes to biodiversity loss and ecosystem degradation.

However, East Africa and other developing nations have a unique opportunity to turn this crisis into opportunity. Through implementing sustainable policy and investing in renewable energy systems and resilient buildings, East Africa can leapfrog industrialised nations, avoiding the process of decarbonisation, and fast-track to a greener and more prosperous future.

## CLIMATE CHANGE

According to the IPCC, East Africa is among the world's most vulnerable regions to the impacts of climate change.

The climate in most of East Africa is relatively benign i.e. temperature and humidity levels are comfortable for much of the year compared to areas with much more extreme conditions. However, with the rapidity of global warming, weather conditions are likely to become far more extreme. The report 'Impacts, Adaptation, and Vulnerability' by the IPCC, outlined significant risk to the region from a projected increase in hot days and heavy precipitation. Buildings must therefore be designed to mitigate the effects of extreme weather conditions, taking into account regional variations. Online resources can provide easy to understand data on temperature, humidity, rainfall and ventilation throughout the year, which can be used to influence building design and ensure ongoing comfort conditions.

## POPULATION GROWTH

East Africa faces unique infrastructural challenges as a result of high rates of urbanisation and some of the highest levels of population growth in the world.

With an average population growth rate of 6.7% between 2013 and 2017 – double the African average – East Africa is one of the fastest growing regions in the world. This increase in population will put huge pressure on the region's cities and overburdened infrastructure, and will undoubtedly lead to urban expansion and an increase in demand for new housing and school communities.

This guide focusses on single-storey structures in peri-urban or rural areas, though with the intensification of urbanism it is anticipated that 2-3 storey buildings will become much more common. This will introduce a new range of concerns such as the structural stability of multi-storey structures and the additional cost of stairs and lifts.

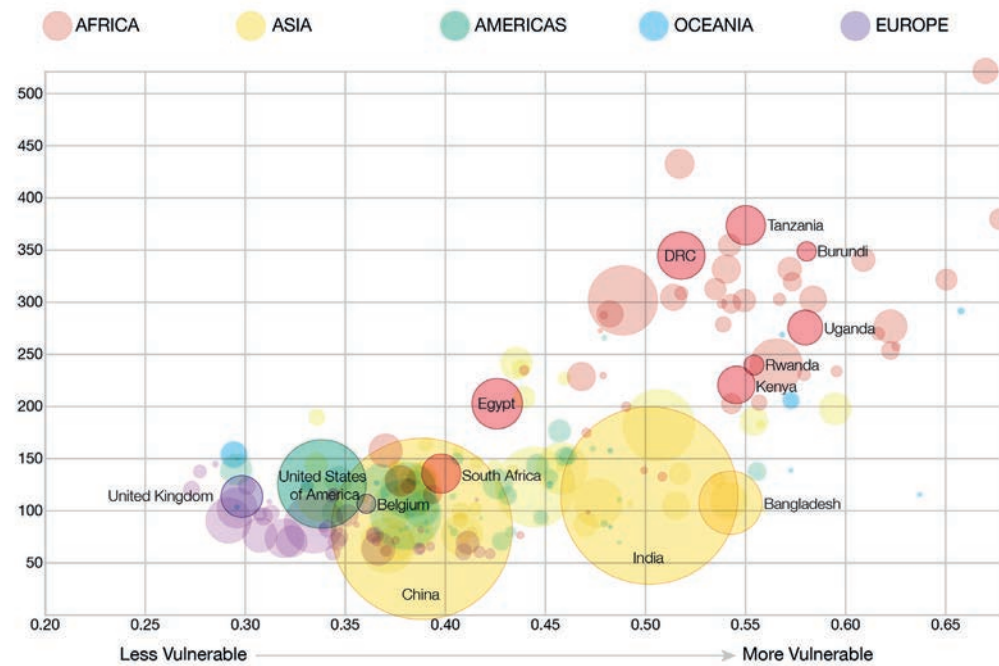

Percentage population growth by 2080 over climate change vulnerability. Circle size represents current population size. Data source UN Department of Economic and Social Affairs 2019

Vulnerability index from the ND-GAIN index. Latest data 2017 <https://gain.nd.edu/our-work/country-index/>

## SCHOOL DESIGN

Most East African schools are thermally uncomfortable to the extent that they create adverse internal conditions that are not conducive to inspired learning.

Typical school buildings are single storey structures with pitched roofs and simple window openings. Unfortunately, they are often thermally uncomfortable, to the extent that classrooms do not function as spaces offering shelter, but create adverse internal conditions. For example, darkly painted or corroded single sheet metal roofs may heat up to 60°C during the day - even in well ventilated spaces. This has negative consequences for a rising new generation requiring good and efficient education. Even more concerning is that as equatorial East Africa will be severely affected by global climate change, the need to design resilient buildings that do not rely on artificial space conditioning will become more and more critical for comfort and inspired learning.



NTC Kaliro Before being renovated and expanded the NTC Kaliro had metal sheet roofing that regularly heated to over 50C

## ELECTRICITY SUPPLY

As schools are typically remote, electricity is not always available, and accessibility is limited. Solar PV provides a sustainable and reliable solution.

Energy use in schools is likely to increase as computers and other electrical equipment become more intensively used and demand grows for the use of buildings outside daylight hours. However, connection to a municipal grid is not always available in rural locations and electrical supply is anything but reliable. Locally integrated solar photovoltaic systems address a certain degree of grid-independence, while being far more sustainable than centralised energy generated through the burning of fossil fuels, or polluting diesel generators that can be damaging to health. Solar PV systems are reducing in costs year on year though they are still relatively expensive. Their advantage is that they run simply on the free and abundant solar energy available in the equatorial climate and produce zero CO2.



Standard solar photovoltaic cells mounted on a 15 degree pitched roof; an affordable, accessible and sustainable energy source

## LOCAL RESOURCES

Imported materials have high embodied energy from transportation and fail to add the same benefit to the local economy as the use of local resources.

East Africa has an overreliance on imported construction materials such as cement and metal sheet roofing. The problem with imported materials is that the added CO2 from transportation contributes towards creating high embodied energy buildings. Comparatively, locally sourced materials have low embodied energy and help to build local economies through job creation, although local materials can become scarce if not managed responsibly. Compressed earth for instance is readily available on most sites, and can provide a low-carbon alternative to fired clay bricks. Timber is a low-to-negative carbon material providing it is part of a sustainably managed plantation where new trees are planted to replace the ones which are cut down for construction.



Ilima Primary Cement-free mudbricks were made with earth from nearby termite mounds to create a stronger cohesion

# THE REGIONAL CLIMATE

The starting point for any design project is an understanding of the brief, the site and the context. This includes the microclimate - not only now but in the future. This understanding is crucial to the creation of sustainable buildings that can provide comfort even in extreme weather conditions.

The data on these two pages is taken from the online resource Weather Spark, which provides typical weather data for 150,165 locations worldwide. While there is an array of climate resources available online, data is often associated with 'virtual weather data'; typically an interpolation of real existing weather stations farther away. The reliability of this weather data should be understood, in particular as data related to wind directionality may be locally variable. Prevailing winds should be checked against local experience on site, taking local topography into account. Learning from locals, and if possible, installing a weather station at an early stage can help to identify the very local climate characteristics relevant for building orientation.

For more information see:  
<https://weatherspark.com/compare>  
[www.meteoblue.com](http://www.meteoblue.com)

## TEMPERATURE

The climate of East Africa is rather atypical of equatorial regions and weather conditions can vary considerably over only a short distance.

The graph below shows the daily average high and low air temperatures throughout the year for four selected cities in Uganda. This data can be broken down into monthly averages through the online resource weatherspark.com.

Temperatures can be seen to be highest in the north and coolest in the south at Kabale, where the altitude is higher. It is noticeable that there is a reasonable temperature difference throughout of around 10°C between day and night. This means that buildings with high levels of thermal mass and permanent ventilation openings will benefit from night-flushing and stay cool into the next day.

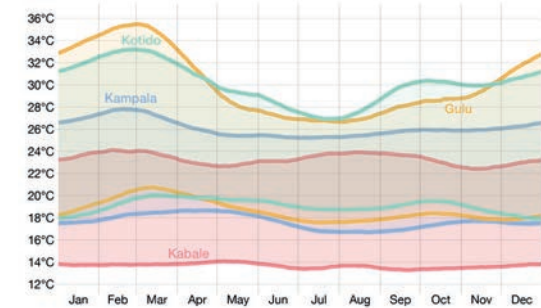

Average high and low air temperatures throughout the year for four different cities in Uganda

## SOLAR RADIATION

East Africa receives a great deal of sunshine each month, which is useful for providing continuous energy supply through solar PV and solar thermal collectors.

In temperate climates direct solar radiation helps improve comfort conditions when air temperatures are too low. Buildings can act as solar collectors to attract and store heat from the sun. In East Africa, however, temperatures are generally comfortable, while the graph below shows that solar energy is consistently high throughout the year at 5-7 kWh/sqm. This means it is more relevant for buildings to provide shading from the sun so that direct solar radiation isn't translated into overheating. The abundant sunshine can however, be beneficial in terms of providing a continuous energy supply both for solar photovoltaic systems and solar thermal collectors.

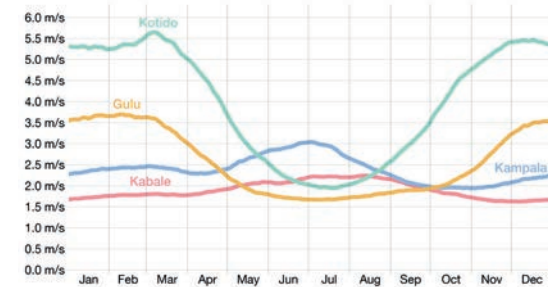

Average daily incident solar energy throughout the year for four different cities in Uganda

## PRECIPITATION

Much of East Africa has typically two rainy seasons through the year which is great for growing plants but not so good for providing continuous water supply.

The graphs show that in Kampala and southern Uganda there are generally two rainy seasons in March to May and September to December. Further north the rainfall tends to be greater from April to December. Rainfall brings with it higher humidity, the graph showing the incidence where the relative humidity is above 65% shows that in the central region around Kampala and on the shore of Lake Victoria, excessive humidity is a problem in the early summer, requiring buildings to be designed to maximise air movement.

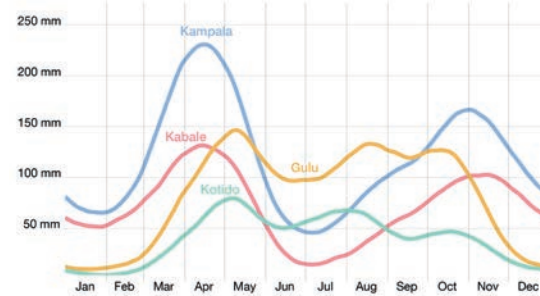

Average monthly precipitation

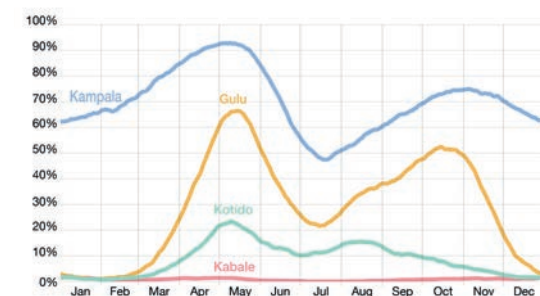

Chance of muggy conditions

Graphs showing prevalence and severity of rain and humidity throughout the year for four different cities in Uganda

## WIND

Wind data can provide a starting point for locating ventilation openings but should be considered alongside local experience on-site.

The graph of windspeed gives an idea of the comparative difference between Gulu and particularly Kotido, where wind speeds are relatively high and can be used to counteract overheating, and Kampala and Kabale where wind speeds are quite modest. A wind rose describes both the wind speed and direction and therefore gives an idea of the cooling potential of natural ventilation. The illustration below shows the predominant wind direction in Kampala is from the south and indicates the number of hours per year that the wind blows from each direction.

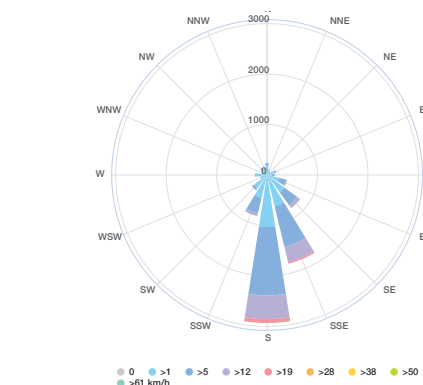

Wind Rose Kampala Meteoblue

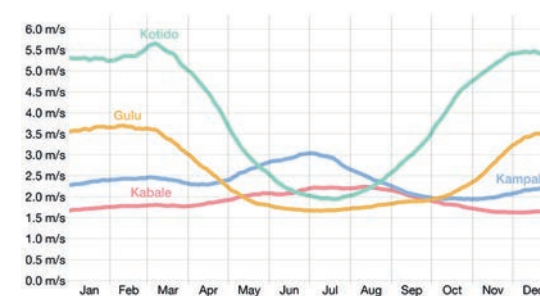

Average wind speed

Meteoblue. Climate (modelled) Kampala. URL [https://www.meteoblue.com/en/weather/historyclimate/climatemodelled/kampala\\_uganda\\_232422](https://www.meteoblue.com/en/weather/historyclimate/climatemodelled/kampala_uganda_232422). Visited on 26.07.2019.

## COMFORT CONDITIONS

While some areas of East Africa are consistently comfortable, others require the benefit of thermal modification that a well-designed building affords.

These graphs show at a glance what time of year and time of day you are likely to encounter uncomfortable climatic conditions at each of the four locations, with uncomfortable air temperatures, shown in red. It is evident that whereas in Kabale the air temperatures are tolerable throughout the year, in Gulu one would be looking for shade and air movement to provide natural cooling from December through to April, while in Kotido this would be desired from mid-September to April. Fortunately in both these areas windspeed is relatively high at that time of year.

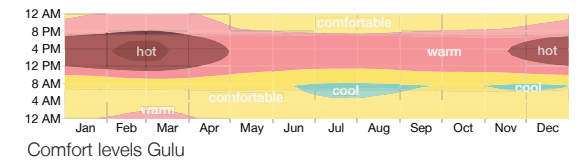

Comfort levels Gulu

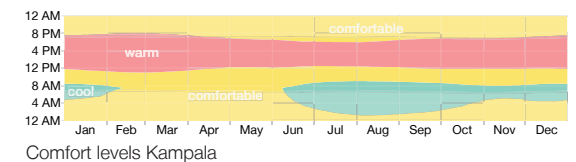

Comfort levels Kampala

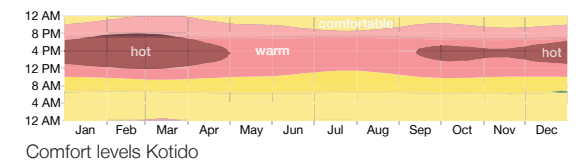

Comfort levels Kotido

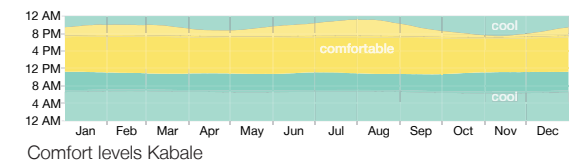

Comfort levels Kabale

Comfort conditions throughout the year for four different cities in Uganda



## 2 PARTICIPATORY PROCESS



# PARTICIPATORY DESIGN

Climate responsive design is fundamentally a participatory process, requiring collaboration between client, community, and the private and public sectors.

A participatory process must be dynamic, integrated and respectful, and attempt to actively involve all stakeholders (students, families, teachers, local community, local authorities etc.) through all project stages, to help ensure that the end result meets their needs. By incorporating a wide variety of views there is greater opportunity for successful outcomes.

This bottom-up approach is an effective way to improve sustainable hardware and software, building local capacity through the process of design and construction. Participatory design results in low-carbon, long-lasting buildings that effectively fulfil the needs of users and enhance lives in the local community.

## THE ROLE OF THE ARCHITECT

*Architects are not makers of things but people who evolve the capacity of places and communities.*

Pursuing a democratic approach to design removes control from the architect and redistributes it to end users and members of the local community. To curate such a process requires significantly less ego and more ethos from the architect. Rather than being concerned with the production of beautiful buildings, participatory design prioritises the consequences of architecture over the objects of architecture. Designers must understand not just what buildings are, or how they are made, but what they can do.

In participatory design, the architect is responsible for designing the process by which the potential of a community is manifested. Material things like buildings or streets can be part of that design, but only insofar as they serve a larger purpose. For the process to work, architectural responsibilities must expand from design and construction to visioning through to evaluation, encompassing pre-design services and post-occupancy analysis. This end-to-end participatory process results in high quality, affordable and healthy buildings. Design becomes a tool to empower communities and lead to a stronger, prosperous and more sustainable future.



**Lake Bunyonyi Secondary** An architect leads a visioning workshop for potential new school facilities

CASE STUDIES

3 5 8

## IMPACT DESIGN METHODOLOGY

*Every project is an opportunity for positive systemic change and the transformation of policy and behaviour.*

When commencing a project, the new question for sustainable design should not be how we construct buildings, but why? What is their social, environmental or political value?

Impact Design Methodology is the process by which the unique circumstances surrounding each project are turned into a means for systems transformation. The participatory process begins at the pre-design stage by collectively defining the problem and focussing ideas for solution. This results in a single aligned mission with a shared understanding of stakeholder needs and goals and should encourage broad and realistic expectations of what the project can do. Next, the method or means to achieve the mission must be decided. This is about harnessing unique opportunities for empowerment, creating linkages between stakeholders, engaging suppliers and working with and supporting local organisations. Finally, metrics should be identified by which the mission will be evaluated. This feeds into post-occupancy analysis to decide if a project has been a success, and provides the data that is needed to influence policy and create lasting behavioural change.



**Ilima Primary** Improved facilities led to an increase in student attendance of over 30%

CASE STUDIES

3 9

## IMMERSION IN CONTEXT

*Learn to understand the potential of a place and community through total immersion in the context. Places are unique living organisms.*

Any built project has the potential to create value, but often projects devalue places. This is because designers often fail to understand that places are unique living organisms. Adding social, environmental or political value to a place requires learning to recognize its potential, through a deep understanding of the local community, ecosystem and political situation. This understanding leads to environments that are more responsive and appropriate to inhabitants' cultural, emotional and practical needs.

The participatory design process must begin with an immersive pre-design phase, where designers take the time to look, listen and learn without preconceptions by personally engaging members of the local community. It is through total immersion in the context that unique constraints and local opportunities can be identified and turned into a means for empowerment. This human-centred design approach also helps to develop meaningful relationships with end users to better understand their challenges, needs and aspirations, resulting in spaces that are functional, attractive, comfortable, and above all, dignified.



**Ruhehe Primary** ADC fellows studied methods of immersive research to put them in direct proximity with the community

CASE STUDIES

3 5 7

## PARTICIPATION TACTICS

*Find out the specific conditions by which community members feel that they can participate in the design and construction process.*

After building trust and understanding, the next step is to engage the local community and key stakeholders in active participation. Participation begins with a visioning and planning process, which can take place over three days. This should begin with very general questions, such as 'what is a school?'. Day two moves into project specific issues – 'how does this idea of a school apply to the site?'. Day three should result in an agreed site layout that the architect can take away to develop. Various activities can take place over these three days aiming to engage as many participants as possible. These can range from formal meetings to fun questionnaires and children's drawing sessions.

Once the architect has developed these ideas, community consultation must involve more than just providing information. Designers must regularly iterate the design with the community through presenting drawings and physical models and responding to their feedback. Small community focus groups can be formed to examine and develop specific aspects of the project, giving individuals a sense of ownership and creating a finished product with, not for, the community.



**RLS Dormitory** ASA provided students with physical models to engage and play with in order to gain their feedback

CASE STUDIES

3 5 8

## POST-OCCUPANCY ANALYSIS

*Quantify and leverage the successes of each project. Acknowledge failures and use them to make improvements.*

Architects are very good at designing, building and implementing designs, but they often spend very little time evaluating them once they are built. Part of an exemplary design process is expanding the role of the architect to include evaluation, so that designers can learn from their successes and failures and feed this knowledge into the next project. Architects need to learn to talk about failing; Fail fast and fail often, go back to the drawing board and make improvements. Innovative breakthroughs arise from failure.

Metrics that are identified in the early project stages should be used to measure the success of a project and analyse the role of the built environment on desired project outcomes. In a school building, this may consist of improvements in educational attainment and cognition, student social engagement, or parental and community engagement. The results of this analysis provide policy makers and leaders with valuable information needed to make informed decisions that create lasting systemic change.



**NTC Kaliro** Comfort assessment based on qualitative data has helped to evaluate the building's performance

CASE STUDIES

4 10

# PARTICIPATORY CONSTRUCTION

Participatory construction focusses on the building process as much as the built product to instigate social change and empowerment through sharing knowledge and skills on site.

Designers should take what they learn during the pre-design phase, and use this knowledge of people and place to select building materials and construction systems that build capacity and self-determination in the local community. Building collectively brings communities together, supports local economic growth, empowers individuals and instils a legacy beyond final completion. A participatory project is as much a community development programme as it is a construction site.

## LOCAL FABRICATION

*Hire locally, source regionally, channel investment and prosperity into the community.*

A participatory project should be a celebration of people and place. The project should be locally fabricated; built by local people with regional resources, and be inspired by traditional construction methods. As such, the construction palette and techniques for each project are inherently tied to the site conditions, scaling pre-existing skills and local innovations.

This approach engages the community with every stage of the supply and construction process, reducing embodied energy and promoting local economic growth. Labour-intensive processes of hand production are privileged over the use of energy-intensive imported materials, in order to create opportunities for employment through valorising local craft. As well as supporting local businesses and stimulating new micro-economies, hiring locally and sourcing regionally also ensures that the building is easily maintained if it deteriorates, as there is no requirement to source foreign and expensive materials from further afield. This increases the long-term durability of the building, which further decreases its lifetime embodied carbon emissions.



**Ilima Primary** Labour-intensive processes of hand production were prized over imported construction materials

CASE STUDIES 3 5 7 9 10

## CAPACITY BUILDING

*Leverage the construction process to develop local expertise. Invest in the next generation of emerging professionals.*

During the design phase, designers should identify opportunities for skills training during construction. Strategic material selection for instance, can lead to an increase in the capacity and skills of local craftsmen, through building upon and developing existing skillsets. Masons, carpenters and welders can be educated through on-the-job training to improve local construction techniques. This has a spill over effect on the quality of local construction, resulting in a more dignified, healthy and safe built environment.

The construction process can also provide an opportunity for green skills development, building a greater understanding of regenerative strategies and climate appropriate design solutions. Investing in and training the next generation of architects and designers through experience on a live project empowers socially-responsible and sustainably-minded professionals. This will provide them with the leadership and entrepreneurial skills needed to support future development, and may help to solve some of the infrastructural challenges currently facing East Africa.



**Ruhehe Primary** was the design-build component of a 20-month programme to train impact-design professionals in Africa

CASE STUDIES 2 3 5 7

## RESEARCH BY DESIGN

*Test, research and improve traditional construction techniques and innovate low carbon material solutions.*

The participatory approach uncovers opportunities to innovate with the most basic local materials, creating new and better construction solutions that remain sensitive to their context. The process of stakeholder participation and research by design reveals new knowledge, practices and products, which can be tested and iterated upon on site. The aim is to develop and enhance traditional techniques to build a body of regionally specific material knowledge; the emphasis being on finding affordable, low carbon solutions to building construction.

The proverbial red earth for instance – East Africa's most readily available resource – has been developed into new construction materials such as compressed stabilised earth blocks, rammed earth and earth bag walls. Designers are also finding new ways to turn rubbish into resource through the innovative use of food, agriculture and construction waste. These innovations both reduce costs and the negative impact of construction on the environment. Through innovative design thinking and applied research contextual challenges can be turned into local opportunities.



**Ilima Primary** Research was undertaken into using palm oil and ant-hill clay to strengthen traditional adobe mudbricks

CASE STUDIES 3 8 10

## MODULAR SYSTEMS

*Prototype innovative construction systems that are buildable, adaptable and repeatable to increase a project's impact potential.*

In order to ensure a community can build and maintain a project themselves without any imported materials or labour, the project must be buildable with the equipment, tools and skills that are locally available. Where mechanical tools, cranes and scaffolding are not the local norm, the project should be designed to be easily assembled by a small team of local labourers using manual lifts and simple hand tools. The easiest way to ensure this is by designing a modular construction/assembly system where components are sized for convenient handling.

Breaking a building down into standard easy-to-manufacture components also reduces project costs and improves the accuracy, speed and repeatability of the project. Different aggregation of modules may also result in greater adaptability to different terrains and situations. As such, the project may become a system that is intended to be replicated, which the community can adopt and use for themselves. This can have far more significant and farther-reaching impact than designing a bespoke solution for a specific site.



**Mzuzu Health Centre** The project focus was to provide the client with their own highly affordable DIY construction system

CASE STUDIES 6 10

## EMPOWERMENT

*Advocate for a design and construction process that promotes justice, equality and human dignity.*

There is a tangible relationship between design and dignity, which is manifested not only through an exemplary built product, but also through the process by which a project is built. The construction process should be seen as an opportunity to participate, to empower and to contribute to what is collectively defined as culture. Engaging a community in the collective act of making is a dignifying process that curates a sense of shared responsibility. Each community member's participation throughout construction inspires a greater sense of collective ownership, which is the surest form of sustainability.

This collective process relies on the equal participation of both men and women. By ensuring that at least half of employees are women and prioritising their training and professional certification, the process of construction can act to inspire and educate a new generation of female leaders. As well as stimulating economic growth and improving social dynamics, this benefits the environment, as educating women is considered to be one of the most effective ways to combat climate change.



**Rugerero Health Centre** ASA requested a minimum 50% women workforce for construction

CASE STUDIES 2 5



## 3 SUSTAINABLE MATERIALS

# MATERIAL CONSIDERATIONS

Material choices are often driven by cost and fashion, which can result in unsustainable and climate inappropriate buildings. The ubiquitous metal sheet roofing for instance, seen on rural and urban buildings across East Africa, contains huge amounts of embodied energy and creates acoustic and overheating issues for users.

Designers should look to enhance the comfort and health of building users and identify unique opportunities for training and job creation through material choices. Materials should be selected for their environmental credentials - low embodied energy and the ability to enhance local ecosystems or sequester carbon through their production. The ultimate goal should be to design and construct buildings that generate at least as much energy as they use and have a positive net effect on the local ecosystem.

## ENVIRONMENTAL IMPACT

*How buildings are made can have a significant effect on local ecosystems as well as contributing to the global crises of climate change and biodiversity loss.*

The stress that we are placing in the global environment comes from three sources. Firstly we are extracting materials from beneath the earth and releasing stored carbon into the atmosphere. Secondly the organic chemical processes that are now part of our world - from the production of plastics to persistent pesticides - are overloading natural systems with materials that do not break down in nature. Thirdly we are dramatically changing the world's natural ecosystems and causing species extinction at an unprecedented rate. All materials used in construction need to be evaluated against these criteria.



**AWF Primaries** The design uses natural materials and aims to be as light touch on the landscape as possible

## EMBODIED ENERGY

*The energy used to construct the built environment in East Africa is one of the region's major contributions to global warming.*

In much of the world the amount of 'operational' energy we use in our buildings, and therefore the carbon dioxide emissions from them, is a much greater issue than the amount of energy that goes into constructing them. In the relatively benign climate of East Africa this is not the case: the 'embodied energy' that goes into construction is more significant. The manufacture of cement makes it the most carbon intensive building material but the firing of bricks is also highly problematic, particularly if it also results in irreplaceable tree loss. By contrast timber from sustainably managed sources is a way of embedding CO2 in construction.



**Ilima Primary** has virtually no embodied energy - built entirely with simple hand tools and local materials

## USING LOCAL MATERIALS

*Use local materials and local labour, both to avoid the energy cost of transportation and to support the local economy.*

Local materials are often scarce resources and when translated into building materials it is important to consider whether their loss is a problem, or whether they can easily be replaced. Soil from the site is the most basic sustainable material to build with, followed by materials that are grown, such as timber or bamboo, but only providing they are part of a managed ecosystem. Providing resources are extracted responsibly, sourcing materials from on or around the project site can have numerous benefits which are outlined in more detail on page 19.



**Ilima Primary** 99% of materials were sourced from within 10km of the project site

## AVOIDING WASTE

*Adopt a 'cradle to cradle' philosophy and build with materials that are recycled or recyclable in order to avoid wastage of both materials and energy.*

Traditionally architectural materials were repaired and reused until they effectively decomposed, the timber rotted, or the bricks turned back to earth. A newer more resilient generation of building materials like concrete is much more difficult to recycle, particularly if it is mixed with steel reinforcement. The use of plastic materials with a limited life is becoming a major problem globally and we need to look at reducing production, creating ingenious reuse and opening up recycling pathways, rather than turning buildings into waste.



**Ruhehe Primary** Scaffold poles from construction were upcycled into play equipment, water tank screens and fences

## BUILDING TYPOLOGIES

*This guide looks primarily at the structure, materials and environmental design of low-cost single storey rural school buildings.*

Building typology is a significant driver for structural systems and materiality. Simple single storey buildings with loadbearing walls are likely to be dominant typology for schools in East Africa for the next decade or two. As urbanisation increases and land becomes scarcer the need for two and three storey school buildings will begin to emerge, particularly in areas of higher density. Those buildings are likely to be reliant on in-situ concrete or steel as a way of providing safe, fire resistant and earthquake proof construction.



**Lake Bunyonyi Secondary** The boys dormitory building is an atypical 2-storey concrete structure

# FLOORS AND FOUNDATIONS

There is an old saying that the main thing every building needs is a good set of boots and a good hat. The boots are there to provide strong and waterproof foundations, the hat is there to provide protection from sun and rain.

Cement has revolutionised building construction over the last century both in the construction of multi-storey buildings and in the production of durable and waterproof foundations. However, the cement industry is responsible for 8% of global anthropogenic CO2 emissions, making it the third biggest contributor to global warming after energy production and transportation industries. Developed economies are consequently looking for ways to reduce the cement content of buildings and find low carbon solutions to building construction. Foundations are the area where it is most difficult to devise substitutes, but engineering to minimise the volume of concrete is a good starting point.

## STONE

*In the days before cement, stone provided the traditional foundations for a building. If local stone is available it is generally the most sustainable option.*

A foundation for a single storey building is usually created by cutting a trench through existing ground to a depth of 600-900mm and around 450-600mm wide. Filling this with stone reinforces the ground underneath the loadbearing external walls and reduces the possibility of subsidence. Rocks can be used without cutting or 'dressing' providing that smaller stones are used in between to provide a stable base layer. Generally the layer of stones is then capped by a ring beam of reinforced concrete to provide a level base as a datum for the floor slab and external walls.



**AWF Primaries** The schools are built on traditional rubble stone foundations - without the use of concrete

CASE STUDIES

3 9

## CONCRETE

*Use concrete and cement sparingly. Cement is expensive and its manufacture is one of the primary causes of global warming.*

Concrete is composed of cement, sand and aggregate in a typical ratio of 1:2:4. It is the strongest material to use for both foundations and ground floor slabs and good quality concrete has waterproofing capabilities - though this can be improved by incorporating a plastic sheet as a damp-proof membrane. Unfortunately, cement is an imported material which is both expensive and unecological, producing substantial quantities of carbon dioxide in its manufacture. Efforts should be made to limit the use of concrete wherever possible and use cement sparingly.



**Lake Bunyonyi Secondary** Bricks were inlaid into the first floor formwork to reduce the amount of concrete required

CASE STUDIES

5

## LIMECRETE

*Concerns over the industry's increasing carbon emissions have led to a resurgence of lime as an alternative binding agent to cement.*

Although cement has been the conventional binder since the 20<sup>th</sup> century, lime was the traditional binder for centuries before that. Lime is not as strong as cement, nor does it have the same waterproofing qualities. However, this can be an advantage as lime is hygroscopic giving it the ability to effectively regulate temperature and humidity. Lime requires less energy in its production than cement and sequesters carbons as it hardens. The recommended mix is 1:3 of lime to a sand and aggregate mixture. Limecrete can be used to create floor slabs and consolidate a stone foundation to provide the footing for walls and frames.



The Pantheon Temple in Rome has a limecrete dome spanning over 43m that has survived nearly 2000 years

CASE STUDIES

## EARTH

*Earthen floor technology has progressed significantly from unsanitary dirt flooring and now represents a cost effective and durable alternative to concrete.*

Consolidated earthen floors simply use the material excavated from site as a result of digging foundations. However, unlike traditional dirt flooring, cement-free earthen flooring is durable, waterproof and washable. The earthen floor system, which has been developed by Earth Enable, is made from different layers of compressed natural material sealed with linseed oil, which permeates the fine earthen mix and forms a waterproof and plastic-like resin on top. Earth Enable predicts that in the East African climate earthen floors should last 10-15 years if maintained with a fresh coat of oil every 3 years.



**RLS Dormitory** ASA collaborated with Earth Enable to produce cement-free sustainable earthen flooring

CASE STUDIES

3 8

## TILES

*Concrete, ceramic or clay tiles and bricks can provide a durable and decorative floor surface.*

A ceramic tiled floor on a concrete slab provides a very durable, though expensive, floor finish. Production of ceramic floor tiles is carbon intensive due to cement content and the energy required for firing. A fired brick or concrete tile floor laid in cement or lime mortar will be less costly and more sustainable but more difficult to keep clean. Compressed earthen floor tiles, stabilised with a little cement or lime are more sustainable still but remain an uncommon and relatively undeveloped technology.



**Ruhehe Primary** The cement floor tiles contain volcanic stone dust as aggregate to reduce costly sand and gravel content

CASE STUDIES

7 10

# WALL MATERIALS

Most new buildings of any size require a frame to stabilise the walls and deal with earthquake resistance and wind loading. Brickwork or blockwork buildings therefore require piers at regular centres (generally around three meters) that link into a foundation and a ring beam at eaves level. Piers can be made by increasing the area of brickwork or bricks can be spaced out to act as permanent shuttering for a reinforced concrete column.

Concrete is not generally recommended as a wall infill due to the high cement content in concrete blocks, mortar and the cement render required to finish the wall. East Africa's proverbial red earth provides numerous low carbon alternatives to concrete, which may be as simple as mud mixed with straw to make cob, or soil stabilised with lime or cement. Earth construction is more efficient with pre-formed mudbricks, compressed earth blocks, earthbags or fired clay bricks.

For more information see:  
<https://www.teachamantofish.org.uk/assets/images/assets/uploads/Brick-Making-Business-Guide.pdf>

## FIRED CLAY BRICKS

Large clay reserves have made fired clay bricks the preferred construction material in East Africa. Take care to ensure bricks are manufactured sustainably.

Local handmade bricks are sundried and fired in firewood-hungry roadside kilns in an inefficient process that is contributing to widespread deforestation in the region. An alternative manufacturing process utilises waste materials such as cassava peel or coffee husks as the primary energy source for firing bricks. This process is undertaken in small-scale industrial brickwork factories, with the added benefit that factory-made bricks are more dimensionally accurate than the handmade alternative. Consequently, factory-made bricks use less cement mortar and can be laid to a fair-faced finish so they don't require an external coat of cement-based render.



**Lake Bunyonyi Secondary** Bricks were moulded from good quality clay and sundried before being stacked up into giant furnaces

CASE STUDIES 1 2 4 5 6 7 8

## STABILISED EARTH

Earth can be strengthened using a 5-10% cement or lime stabiliser and compacted into earthbags or rammed earth walls.

In order to be suitable for stabilised earth construction, soil must have a low clay content of less than 15%, although soil with higher clay content can be supplemented with additional sand. Low-density stabilised earth will be porous and weak so the stabilised mix must be manually or mechanically compacted. The 'rammed earth' technique uses powered tampers to compact the semi-dry soil mix into temporary formwork. For earthbag walls this mix is packed into degradable sacks, which are laid end to end and manually tamped into earthbag courses. A loop of barbed wire is laid between courses to act as mortar. Unlike rammed earth, earthbags require additional plastering with cement or lime render.



Fresh rammed earth wall produced by Hive Earth - a specialist earth construction company based in Ghana

CASE STUDIES 9 10

## STABILISED BLOCKS

Stabilised earth can be compressed into dimensionally stable building blocks for easy and efficient construction.

Compressed stabilised earth blocks (CSEB) are comprised of stabilised soil mix compressed by diesel or man-powered machines into solid building blocks. CSEB are strong and dimensionally stable but like fired bricks require a 12mm cement mortar joint to hold them together. Interlocking stabilised soil blocks (ISSB) are compressed into a stepped profile, which allows them to interlock vertically and horizontally to their adjacent unit eliminating the requirement for cement mortar. ISSB are an extremely sustainable option, but the block shape limits design flexibility and buildings can suffer architecturally from an unresolved corner solution.



**Mzuzu Health Centre** Phase 1 uses a mechanical hydraform press to produce interlocking stabilised soil blocks

CASE STUDIES 9 10

## WATTLE AND DAUB

This traditional material could be revived providing the underlying structure is sourced from a sustainably managed timber plantation.

Wattle and daub is an ancient construction method, where a well braced timber frame with small scale timber laths, known as the wattle, is daubed with a sticky soil mix containing clay, sand, animal dung and straw. Wattle and daub walls are well insulated due to the high straw content but they lack the thermal capacity of solid masonry walls. Daub render can be strengthened with the addition of lime or cement or the wall can be whitewashed to increase resistance to rain. As long as the underlying structure is responsibly sourced, wattle and daub is a cheap and low-impact sustainable building option.



Living Tebogo by Base Habitat adapts vernacular wattle and daub construction (above) to produce a unique finish (below)

CASE STUDIES 7 9

## STONE

Stone construction is relatively uncommon but where local stone is available it can be a sustainable option for wall structure or cladding.

East Africa has an impressive variety of stone - from sandstones, quartzites and granites to the remarkable Karamoja marble. The predicament surrounding stone as a construction material on a larger scale is the absence of professional mining infrastructure and industrialised mass production. This is largely reducing the use of stone to cladding or for external works. However, once a certain roughness is accepted, locally sourced stone can be used structurally without having to deploy heavy machinery.



**Ruhehe Primary** Volcanic rock is built around a central core of steel and concrete to guarantee stability

CASE STUDIES 7 9

# WINDOW OPENINGS

Windows provide daylight, ventilation and a view to the outside. They are the eyes and nose of internal spaces, filtering light and air. Windows are key to the environmental performance of buildings, which is covered in more detail in Part 3: Bioclimatic Design.

Windows and doors are the moving parts of a building and as such they need careful design for minimum maintenance. As windows are usually openable, material consideration should be given to security, privacy and protection from the elements. Windows are more weatherproof when they open outward but side-hinged casements can obstruct space outside the building. Top hung casements provide useful high level ventilation. Centre pivoted windows can be better balanced for ease of opening, and when horizontal, can bounce light deeper into the room.

## FRAMING

*Timber and steel are the most logical materials to use for opening windows and doors. Framing should be locally fabricated so that it can be easily maintained.*

Much of the rest of the world has an appetite for plastic windows but these are oil based and are difficult to recycle. Aluminium extrusions are also very energy intensive but are potentially more robust. Locally made timber or welded steel windows invest in the local economy and ensure that maintenance is locally available as it is often the moving parts of a building that are most susceptible to wear and tear. If using timber, this should be sourced from sustainably managed plantations where the trees are replanted regularly.



**ECD&F Centres** Brightly coloured playful window framing adds character to the stimulation classrooms

CASE STUDIES 2 3 6

## GLAZING

*Glass is fragile and may not be the right solution for school buildings where the primary function of a window is to provide ventilation.*

As temperatures in East Africa are generally benign, glass could be seen as unnecessary given there are other ways to stop driving rain. Louvred glass windows provide the maximum opening ventilation for minimum obstruction but ideally require toughened glass for greater safety, which is expensive and can shatter on impact causing injuries. Clear plastic sheet (acrylic or polycarbonate) will probably last longer in a school environment though it can scratch and yellow with age. Glass is made from sand, while plastic is made from oil based chemicals; both are energy intensive.



**Mzuzu Health Centre** Mechanical glazed louvres provide both natural daylighting and passive ventilation

CASE STUDIES 2 4 6 10

## SCREENING

*Bamboo screens or woven materials can provide a sustainable and attractive alternative to glazing.*

Where glass or polycarbonate is not available or a low-carbon natural alternative is preferred, bamboo or vines can be woven into frames to create a perforated screen in place of glazing. This has the added benefit of permitting air flow and can help to screen direct sunlight. Bamboo and other natural fibres should be treated with borax or by a traditional soaking and smoking method before use. Alternatively, recycled materials such as plastic or metal waste can be woven into a colourful and waterproof lattice.



**Ilima Primary** Peeled Lilian vine was dried and woven into Lifake hardwood frames to provide screening.

CASE STUDIES 3 7 9

## SHUTTERS

*Shutters can provide louvred ventilation as well as wind and rain protection and can help to moderate light levels.*

Sliding or folding shutters can provide security, protection and variable daylight control without the need for fragile and expensive glass. Steel or timber shutters with louvred slats can admit a small percentage of daylight and allow free-flowing air movement without letting in rain. Vertically folding shutters let light in at the bottom of the window but prevent direct overhead sunlight from entering the room. Sliding shutters are easier to install and use if they have high quality roller mechanisms.



**Lake Bunyonyi Secondary** Classrooms have wooden shutters instead of glazing that can be manually pushed open or closed

CASE STUDIES 1 5 9

## INSECT NETTING

*Mosquito netting may be necessary in some areas, particularly for buildings that are used in the evenings or night-time.*

Many low cost buildings are unlikely to be well-sealed enough to prevent mosquitoes finding a way in so the provision of mosquito netting at windows is unlikely to be useful. With well-constructed buildings which are used during the evenings or for dormitory buildings, adding a layer of mosquito netting at the window can avoid the use of netting around beds. It is worth remembering that insect netting reduces daylight and restricts air movement and daylight considerably so window openings will need to be larger in order to compensate for this.



**NTC Kaliro** A layer of framed mosquito netting can be opened or closed independently of the glazed windows

CASE STUDIES 4



# ROOF BUILD-UP

Roofs in climates with excessive amounts of sun and rain are best thought of as broad brimmed hats - extending way beyond the supporting walls to provide shade and discharge of what can amount to excessive amounts of rainwater.

Conventional classroom buildings require roof trusses that span seven to nine meters between side walls and are typically clad in roof sheeting which requires roof purlins at approximately 90cm centres.

The pitch of a sloping roof needs to be greater than ten degrees for roof sheeting. Tiled roofs require more supporting timberwork and should be steeper at around 25 degrees in order to shed driving rain. Thatch should ideally be over 40 degrees.

## ROOF STRUCTURE

Roof structure should be efficient, functional and beautiful. Considered roofing design can add a lot of aesthetic character to a space.

Roof structure usually consists of prefabricated welded steel or bolted timber trusses, spanning between columns built into loadbearing walls. However, this is not always the case and roofs may be supported via a reciprocal structure or composite roof cassettes. Home grown timber is rarely more than three to four meters in straight lengths so shorter lengths of timbers are scarf jointed or lapped and bound in metal straps. Light steel angles and tubes welded together provide a more durable, though a more expensive structural solution.



Rugerero Health Centre (above) Lake Bunyonyi (below) Welded steel trusses and a reciprocal timber roof structure

CASE STUDIES 1 2 3 4 10

## SHEET MATERIALS

Corrugated metal sheeting has become the default material for low cost roof covering for school buildings.

Metal sheet roofing needs to be galvanized or powder coated to prevent rusting. A galvanized or light coloured finish will reflect solar energy and substantially reduce heat gain, although metal roofs often result in substantial overheating issues. A more sustainable and climate-appropriate alternative is bituminous corrugated sheeting or Onduline, which is made from recycled cellulose fibre and has better thermal and acoustic properties than metal sheeting. Sheet materials need to be fixed through the ridges using rubber or plastic washers to seal around the fixing. Proprietary bent sheets provide waterproofing for hips and ridges.



Mzuzu Health Centre 10.7m lengths of shiny galvanised 'alu-zinc' roofing sheets help to reflect solar radiation

CASE STUDIES 1 2 4 8 10

## NATURAL MATERIALS

Thatch and shingles are a traditional roofing material across many parts of East Africa but the sources of supply are getting scarce and less sustainable.

The best thatch is made from reeds, though straw and palm fronds can also be used. Bamboo or wood can be split into shakes or shingles and laid in courses like roof tiles. Traditionally natural roofing required a very thick layer of vegetative material to ensure water resistance; contemporary use of thatch or shingles often incorporates a layer of waterproof membrane instead. As with all 'harvested' building materials, thatch and shingles must be sourced from a responsible supply chain. As long as the material is from a renewable source, then natural roofing will contribute towards carbon sequestration and can reduce embodied energy in construction.



Ilima Primary Locally harvested timber was transformed by hand into durable and replaceable hardwood shingles

CASE STUDIES 3

## FIRED CLAY TILES

Fired clay roof tiles provide an attractive alternative to metal sheet roofing. If available locally, clay tiles are arguably more sustainable than imported steel.

Clay tiles require roofing battens at approximately 30cm centres, spanning between rafters at around 60cm centres so a lot more timber is required to construct the roof. The smaller module means there are more joints that could leak but clay tiles have better acoustic and thermal properties than metal sheets, helping to limit the sound of rain and reduce heat transfer to rooms below. As with fired clay bricks, clay tiles are usually produced locally so they contain less embodied energy from transportation and inject money directly into the local economy. Care must be taken to ensure the firing process is undertaken responsibly and sustainably.



ECD&F Centres The fired clay tiles are a sustainable and locally sourced roof covering system

CASE STUDIES 6 7

## CEILINGINGS

Ceilings help reduce the radiation of solar heat from the roof to the space below and can also reduce the acoustic impact of rainfall on the roof covering.

In educational buildings the noise of rain on metal roof sheeting can severely disrupt classroom teaching. A layer of woven grass matting or bamboo screens can dampen down the sound and also provide a layer of insulation to reduce the heat transmission from the roof sheeting. A ceiling fixed below the purlin structure with a continuous airspace of 10 -15cm will further reduce heat transmission particularly if it can be ventilated top and bottom so that moving air can dissipate the heat.



Rugerero Health Centre Umusave wooden planks with damp proof and insect preservative have been used as a ceiling material

CASE STUDIES 2 4 10

# MATERIAL INNOVATION

Innovative new approaches to local materiality are being explored and developed by local architects and built environment professionals in East Africa. The emphasis is on finding low carbon solutions to building construction, through promoting local materials and reducing the cement content in buildings. By shifting from carbon-intensive foreign material imports to local labour-intensive construction techniques, architects can leverage the construction process to develop skills and local expertise, while significantly reducing the embodied energy content of their buildings.

For more information see:  
[www.rubengeracampus.com](http://www.rubengeracampus.com)  
[www.light-earth.com](http://www.light-earth.com)

## ENGINEERED TIMBER

*Adhesives can optimise the structural characteristics of wood and turn short lengths of timber and wood waste into composite panels or beams.*

The use of adhesives can make timber much more useful and reduce wastage by diminishing the negative impact of knots and other small defects. Often the manufacture of these products requires considerable investment in technology, but some techniques can lend themselves to small scale production of high strength materials. The critical issues are making sure the timber is dry and very accurately machined, using the right moisture-resistant structural adhesive and ensuring the curing process is followed carefully. Engineered wood contains more embodied energy than solid timber but far less than reinforced concrete and steel.



At the Rubengera Technical School, Rwanda, they are experimenting with laminated timber as well as I-section timber beams

## LIGHT EARTH STRUCTURES

*Thin, compressed stabilised earth tiles can be formed into parabolic vaults with the ability to span up to 16 meters.*

South African architect Peter Rich along with Tim Hall, and engineer Michael Ramage have developed an innovative shell vaulting technology, which is a fusion of architectural design, advanced structural analysis and labour-intensive local material production. Hydraulically pressed stabilised earth tiles are laid onto a temporary formwork where they are 'glued' together with a gypsum mortar. Several further layers incorporating plastic geo-textiles are applied to create a spectacular self-supporting shell structure. The technology requires careful supervision, but unskilled workers can be easily trained in the technique.

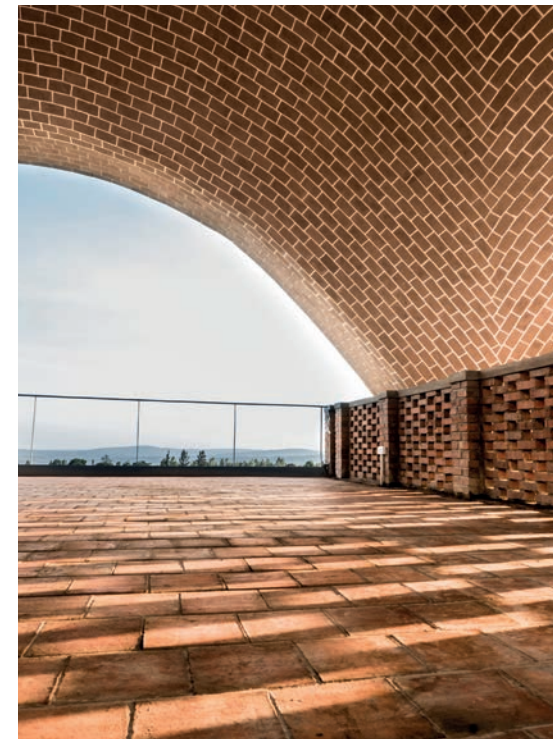

The Rwanda Cricket Pavilion consists of three self-supporting parabolic roofs made from compressed stabilised earth tiles

## STRAWBOARD

*100% recyclable and biodegradable. Strawboard panels are a carbon negative alternative to cement-based loadbearing walls.*

Strawtec panels are a newly available construction material manufactured in Rwanda. The strawboards are extremely robust and offer a high performance, fire-resistant and loadbearing alternative to concrete or fired brick walls. The panels are made from agricultural waste, that would otherwise be burned for disposal, in a dry extrusion process that binds straw together using its own natural adhesives. The process produces zero toxic waste and requires very low energy input. Strawtec aims to stop East Africa's over-reliance on imported materials and instead offer an opportunity to export new construction materials to neighbouring markets.

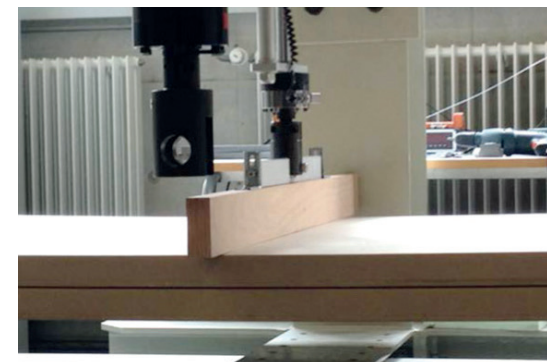

Strawtec recycles agricultural waste into a high performance, carbon negative building product

## BIocreTE

*Organic concrete uses vegetable substances instead of chemical and mineral additives used to produce concrete.*

Biocrete is based on a mixture of natural fibre, residues from agricultural waste and hydrated lime. Rice husks and coconut coir can be supplemented for aggregate, while starch from cassava peel can be extracted and used as an additive to improve the processing properties of concrete. Cassava peels and rice husks can be burned as fuel to produce a pozzolanic ash, which reacts with lime and water to create a sustainable cement substitute. Biocrete is not as strong as concrete and is best used for infill walls and flooring rather than primary structure. However, strategic use of the material can drastically reduce the cement content of buildings.



Possible materials for East African Biocrete: rice husks, ash from cassava peels, karroo gum and coconut fibres

## RECYCLED MATERIALS

*Building with recycled materials is an innovative and cost-effective construction solution that helps to keep the environment clean.*

Waste products can often be reused, upcycled or recycled for use as construction materials. An example of this is the low-tech recycling and innovative application of plastic bottles. These can be filled with sand or stuffed with single use plastic until they reach a high enough density to make them into a solid building block. Plastic waste can also be woven into screens, shredded and compressed into tiles or combined with sand and aggregate to make pavers. Alternatively, whole plastic or glass bottles can be inserted into the wall or roof structure to allow light to penetrate into interior spaces.



The Ross Langdon Health Education Centre uses recycled plastic bottles to create 'litres of light'



## 4 BIOCLIMATIC DESIGN

# SOLAR SHADING

The equator runs across East Africa, through Kenya and southern Uganda. Along the equator the sun at midday is directly overhead throughout the year. This means that in East Africa roofs receive far more solar radiation than walls. Glazing acts as a heat trap by permitting short wave solar radiation to enter but not allowing longer wave thermal radiation to escape. Direct sunlight on windows will consequently cause buildings to overheat. The basis of solar shading principles is to allow diffuse daylight into buildings while shading from direct sunlight.

## ORIENTATION

Orientate buildings to reduce east and west elevations which receive the most direct solar radiation.

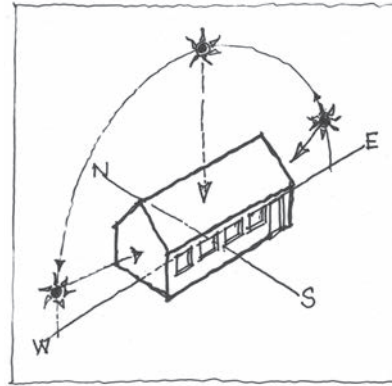

North and south elevations receive hardly any direct solar radiation, though the further north you travel the more the south-facing walls need shading and vice versa. East and west elevations receive low-level solar radiation in the morning and afternoon respectively. This means that these walls by preference should not contain window openings, which should be kept to the north and south façades. Energy efficient masterplanning often results in an east-west grain to the layout of buildings.



NTC Kaliro has a 3-phase masterplan, which orientates all new structures on an east-west axis

CASE STUDIES 3 4 9 10

## OVERHANGS

Use elements of the building such as colonnades and projecting overhangs to shade windows and walls from direct sunlight.

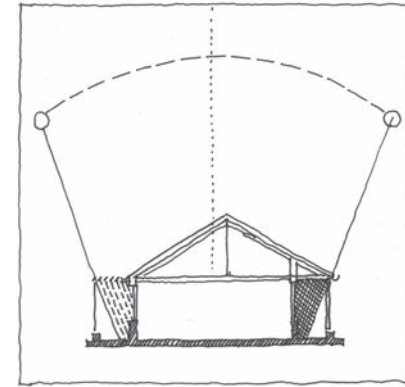

A large overhanging roof will shade windows from direct sunlight and reduce the external surface temperature of the building, which can have a corresponding effect on local air temperature.

Overhangs are particularly important where buildings cannot be orientated on the east-west axis due to topographical constraints. In these circumstances, overhangs can be exaggerated by creating a colonnade around the full circumference of the building or on particularly exposed façades.



NTC Kaliro Large overhangs shade the external walls, reducing solar gain from heating the fired brick walls

CASE STUDIES 1 2 3 4 10

## TREES & PLANTING

Trees and climbing plants can be used to shade exposed windows and walls particularly on the east and west elevations.

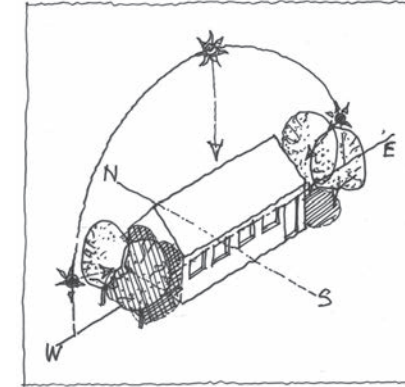

Vegetation can be strategically planted to provide shading for windows, walls and roofs of buildings which would otherwise be exposed to high levels of solar radiation, such as the east and west façades.

The Umbrella tree for instance, has dense and overarching foliage and will easily shade walls and single storey roofs. Climbing plants can also be grown alongside or up buildings, and trained along wires or poles to create a living shading device.



Climbing plants have been trained to grow on the east and west façades of Mubuga Primary School by MASS Design Group

CASE STUDIES 1

## ROOF COLOURING

A shiny or very light roof finish will reflect solar radiation, helping to reduce radiant heat transfer to interior spaces.

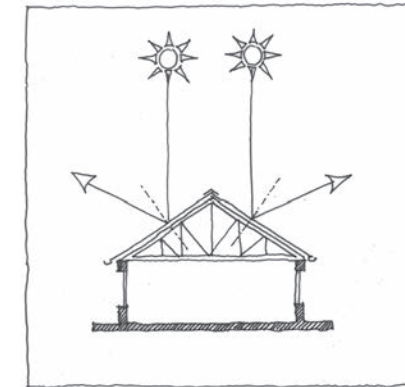

One of the most simple and effective methods to protect against solar gain, is to select a reflective roofing material that helps to limit thermal transfer to the interior spaces. Shiny metal sheet roofing is far better at reflecting solar radiation than any alternative. White or very light coloured roofing is much better than dark colours, which will actually absorb the sun's heat. Clay tiled roofs are less absorbent than metal and will transmit radiation at a far slower rate.



COF Primaries use silver reflective roofing to limit the thermal transfer of solar radiation to the classrooms spaces below

CASE STUDIES 1

## DOUBLE ROOF

Create a second skin beneath the roof to reduce the radiant temperature and help to cool the roof through enhanced ventilation.

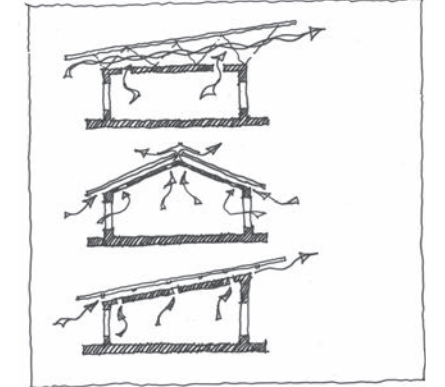

Considerable improvement to the thermal performance of a roof can be made by installing an internal lining or ceiling and ventilating the space between the two. Generally the larger this airspace, the better the ventilation and cooler the internal surface of the roof will be. The ceiling should ideally have some insulation or thermally absorbing characteristics but a ventilated airspace alone provides a significant improvement compared to an exposed single-skin roof.



Gando School by Kéré Architecture has a barrel vaulted brick ceiling shaded by a secondary oversailing metal roof

CASE STUDIES 2 4 10

# PASSIVE VENTILATION

Ventilation is needed in all buildings to remove odours and provide us with oxygen. In hot climates, like East Africa, adequate ventilation is essential to provide cooling.

'Passive' ventilation through windows and opening vents is the cheapest and simplest form of providing fresh air. Where there are problems with ambient noise or pollution, often in more urban locations, mechanical ventilation can be necessary, but passive ventilation should always be the default solution. Openings should be carefully designed to improve thermal comfort.

## PREVAILING WIND

Check wind speed and direction during the hottest season and design to capture prevailing winds.

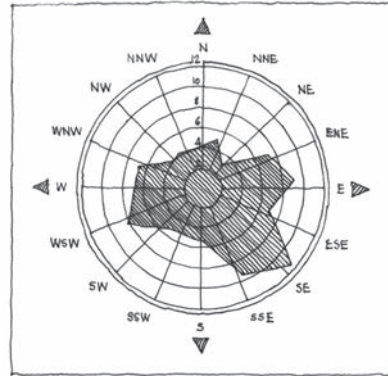

Air movement can have a cooling effect when temperatures are uncomfortably high. Air movement of around three meters per second can provide an apparent cooling effect equivalent to around 2°C. The prevailing wind tends to come from east through to west with a predominance of wind from the south east during the hottest season but there are inevitably significant regional and local variations caused by topography, trees or nearby buildings. Learning from locals, and if possible, installing a weather station during the early project stages can help to identify local wind conditions relevant for building orientation.



Transsolar has installed a number of local weatherstations to determine the prevailing winds on particular sites

CASE STUDIES

## OPENINGS

Ventilation openings can be created using hit and miss bricks, metal, timber or concrete screens or louvres.

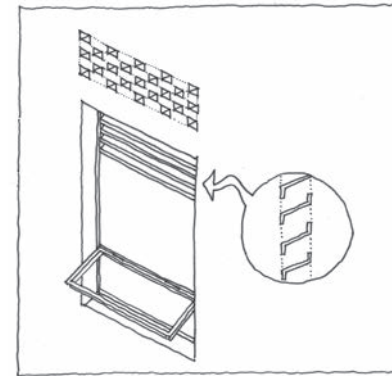

Openings for natural ventilation include glazed casements or shutters, grilles or metal louvres and 'hit and miss' brick openings that are most effectively positioned at the highest level of each space. The aerodynamic free open area (excluding mosquito netting, louvre blades and framing) should be equivalent to at least 10% of the floor area of the room. Louvres should be made to be 'storm proof' with upstands at the back and downstands at the front of a sloping section of metal.



**Nakapiripirit VI** Thousands of louvred blocks create a large surface area of permanent ventilation openings

CASE STUDIES

## CROSS VENTILATION

Windows and vents on opposing sides of a building benefit from wind driven cross ventilation, particularly if they face the prevailing wind direction.

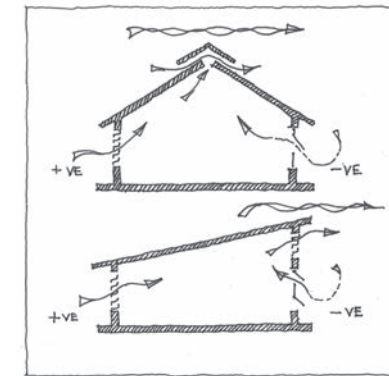

Wind creates pressure differences between one side of the building and the other. This results in air being drawn through openings on the high pressure side and drawn out on the low pressure side. Openings in adjacent walls are less effective at creating air movement than those on opposite walls and single sided ventilation provides even less. Uncomfortably high wind speeds are rare in East Africa so permanent ventilation openings such as hit and miss brickwork can be used to improve thermal comfort.



**COF Primaries** enjoy good cross ventilation due to shallow building depths and generous evenly spaced window openings

CASE STUDIES

## STACK VENTILATION

Buoyancy-driven stack ventilation uses temperature differences to move air. This can be enhanced by solar chimneys driving faster ventilation.

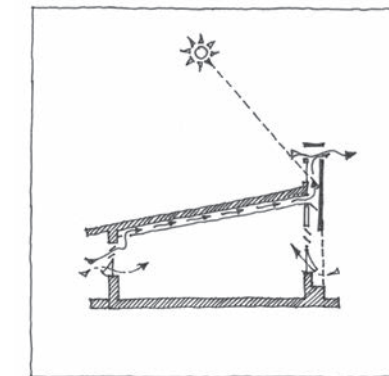

Typically stack ventilation will not induce measurable air movement of any more than 0.5m/s. However, when there is no wind available this is a useful strategy to induce hygienic air exchange. The speed of air movement is proportional to the height of the chimney, measured from above the solar collector to the chimney exhaust. The exhaust must be horizontally orientated with a large free open area in order to maintain a negative pressure, irrespective of wind direction. The whole system must be airtight with a uniquely defined flow path.



**NTC Kaliro** Solar chimneys were designed incorrectly and consequently failed to provide a significant stack ventilation effect

CASE STUDIES

## NIGHT COOLING

Permanent ventilation openings allow cool night air to circulate the building, reducing heat build-up gathered by the structure during the day.

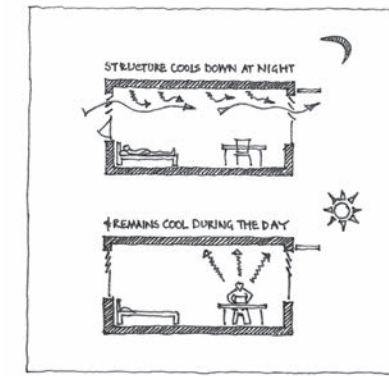

The impact of night time cooling is greater when there is substantial difference between day and night time temperatures. Measured data from earth or brick buildings with high levels of thermal mass shows that peak temperatures in the middle of the day and peak lows in the middle of the night can be reduced by allowing cool airflow through the building at night time. This creates cooler surfaces in the room during the day, which helps to counteract the impact of hotter air temperatures.

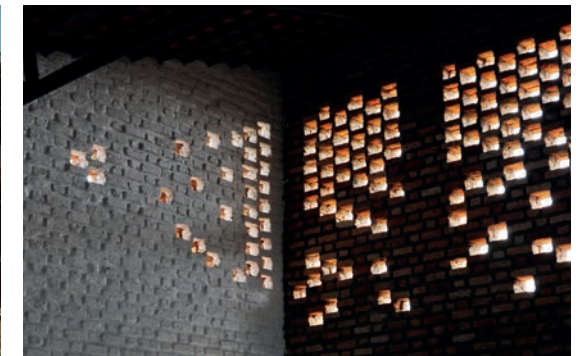

**ECD&F Centres** Permanent openings allow cool air to circulate at night-time helping to reduce heat build-up in the masonry walls

CASE STUDIES

# NATURAL DAYLIGHT

The sun is an extraordinary source of natural light: we only need one hundredth of the amount of direct midday sunlight falling on a desk for us to be able to see very well. Buildings should be designed to use this free resource even where electric lighting is available. As our workspaces and schools become more dependent on computer screens the levels of ambient light can be reduced and too much glare can cause discomfort. Ideally some flexibility is therefore required to control the quality of natural light we admit into our buildings.

## EVEN DISTRIBUTION

Place windows at regular intervals on both sides of the room to achieve even distribution of daylight. Avoid direct sunlight by adequate shading.

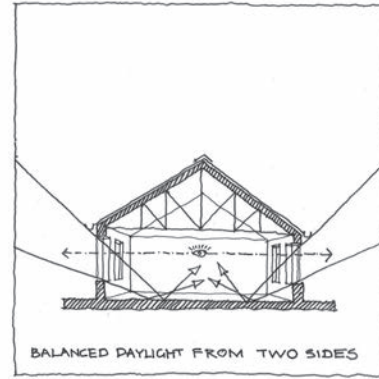

In the absence of electrical light, good quality diffuse daylight is required on working surfaces within a building. In a school this means ensuring that the blackboard, desks and benches where children are working are sufficiently illuminated. Light entering from opposite sides of a room will create a balanced and even distribution of daylight. Windows on the north and south walls are preferred to those on the east and west, as they offer good levels of diffuse lighting throughout the day with minimal direct glare.



**RLS Dormitory** Each bed space in each of the dormitory rooms is equipped with its own personal glass block window

CASE STUDIES 1 2 5 8 11

## DAYLIGHT CONTROL

Blinds and shutters can control the quantity of sunlight and turn glare into diffuse light. Moveable controls allow daylight to be adjusted.

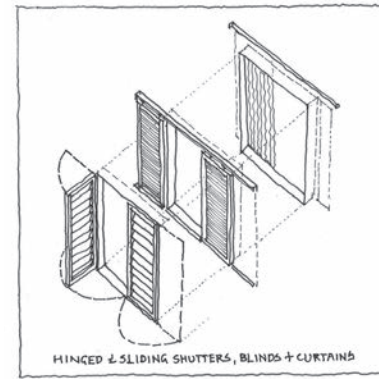

Curtains, blinds or shutters can be used to reduce and diffuse the impact of daylight when it is too bright outside. This is particularly important on east and west facing windows, which suffer from direct solar gain during the early morning and late afternoon. The simplest solution is a louvred or bamboo clad shutter which can be closed to reduce intense sunlight and reopened when more daylight is required. Woven perforated screens can shade direct sunlight while maintaining air movement.



**Lake Bunyonyi Secondary** Windows are fitted with wooden shutters that can be open or closed to control the quantity of light

CASE STUDIES 1 5 9

## ROOFLIGHTING

Roof lights admit two to three times as much light as windows but can cause glare and solar gain if designed incorrectly.

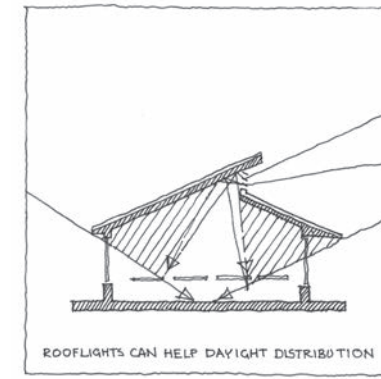

Roof lighting is very useful in deep plan spaces, where work surfaces may be a long way away from windows. A source of light at the central ridge of a roof can bring daylight into an otherwise dark space but it should be protected from direct sunlight. Diffuse daylight can be achieved by screening clear roof sheets with a perforated material or creating a light shelf on the underside of the roof light. Placing a roof light nearby to the backboard wall will ensure that it is kept well illuminated.



**COF Primaries** Polycarbonate is placed on top of perforated metal sheeting to allow light to enter while avoiding excessive glare

CASE STUDIES 1 2 7 9 11

## REFLECTIVITY

The quality of natural lighting in a space is highly dependent on the reflectivity of walls, floors and surfaces within the space.

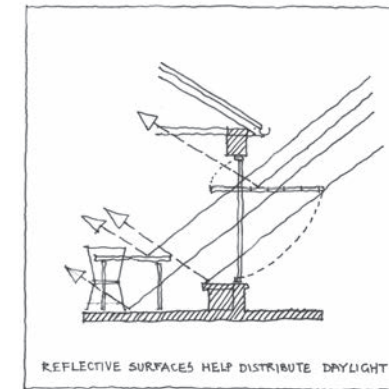

Bright sources of daylight from outside can be transmitted around a space internally by using light coloured walls, floor finishes and working surfaces. This is particularly true of window reveals where highly reflective and light coloured surfaces will amplify the impact of daylight. Conversely dark window reveals can highlight the contrast between light and dark and increase the sense of glare. Light shelves provide shading from direct sunlight, but transmit this back into the room as diffuse lighting.



**Ruhehe Primary** Vibrantly decorated light shelves are hung below the ceiling to bounce diffuse light around the classroom

CASE STUDIES 2 7 11

## ARTIFICIAL LIGHTING

Where spaces are used outside of daylight hours it will be necessary to provide energy efficient artificial lighting.

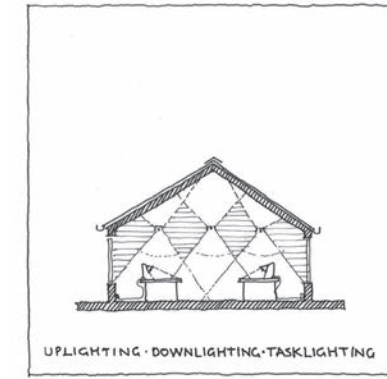

Artificially-lit spaces need to be designed for maximum efficiency to minimise operational running costs. Directing artificial light towards reflective surfaces will ensure efficient and uniform distribution. A room with a light reflective ceiling, for instance, will benefit from up-lighting, whereas in a room with a dark ceiling, luminaires should be focussed on lighting working surfaces. LED bulbs are twice as efficient as fluorescent fittings and ten times as efficient as tungsten light bulbs.



**NTC Kairo** Classrooms have light coloured walls to optimise daylighting and artificial lighting when in use

CASE STUDIES 4

# SUSTAINABLE LANDSCAPE

Many schools have untapped assets such as land, natural resources, sunlight and rainfall that are often ignored and under-utilised. Landscape design should not be overlooked, as strategic masterplanning can have considerable cost benefits as well as improving academic performance, comfort conditions, and the health of students and the wider community. Increase in the quality, quantity and biodiversity of the landscape around buildings is part of an holistic approach to sustainable design.

## OFFSETTING & REGENERATION

*Offsetting the negative impact of development is essential to maintaining the health of both the local ecosystem and the planet.*

The synergy between man and nature needs to be recognised in masterplanning and architectural design. A building development, no matter how well executed, is very unlikely to totally avoid the use of fossil fuels. This carbon footprint can be offset through carbon sequestration from the planting of multiple trees and plants. Planting native trees and keystone species in particular, such as Ficus, can have a disproportionately large effect on the health and abundance of the local ecosystem.



**Mzuzu Health Centre** New saplings were planted to replace the few trees that had to be felled during construction

CASE STUDIES 9 10 11

## PRODUCTIVITY

*Cultivation can form a useful part of the school curriculum. Food production should be seen as a basis for healthy eating, education and cost saving.*

Kitchen gardens and orchards can be hugely beneficial for learning, nutritional health and reducing the cost of school meals. Children can learn about improved cultivation practices through the integration of an environmental and nutritional curriculum. Trees can provide fruit at break times and seasonal vegetables can supplement meals, with any surplus providing an income stream for the school. Managed woodland plantations can be harvested on a regular basis, creating a carbon neutral fuel source for cooking.



**ECD&F Centres** Kitchen gardens have been designed to provide at least one healthy meal to the children of each community daily

CASE STUDIES 5 6 9 11

## ACTIVE LEARNING

*Outdoor teaching areas encourage both work and play. Informal seating under verandas or trees provides additional active learning space.*

Difficulties with abstract thinking and spatial perception have been scientifically linked to a lack of stimulation in childhood. Designing an environment that encourages children's sensorial stimulation is integral to a school's academic success. As an extension of the interior classroom, trees can be planted in circles and crescents to provide shaded outdoor space for teaching, group work and play. Using steps and amphitheatres formed around natural features can embed learning and valuing the natural world into a school's ethos.



**ECD&F Centres** All sites are provided with a selection of custom made playground equipment to promote play-based learning

CASE STUDIES 6 7 9 11

## CLIMATE COOLING

*Trees and plants provide a substantial local cooling effect through shading and transpiration, which reduce radiant heat and increase cool airflow.*

Through integrating plants and trees into the masterplan, a school can benefit from improved comfort conditions through shading from direct sunlight and evaporative cooling. Trees transpire water through their leaves, which removes heat that would otherwise contribute towards warming the local environment. This creates a cooling effect that can contribute to a decrease in local air temperatures of several degrees. Evaporative cooling reaches its peak when evaporation levels are at their highest, usually around midday.



**COF Primaries** Classrooms are located amongst an abundance of mature trees that provide shading and evaporative cooling

CASE STUDIES 1 2

## MITIGATION

*Strategic planting can be used to mitigate damage from potential climate disasters, such as storms, earthquakes or flooding.*

Site specific mitigation tactics should be employed to reduce negative impact arising from severe weather conditions. Wind break plantations can shelter a school during storms, while the creation of bioswales can help to manage large amounts of storm water. On sloping sites, landscape stabilisation will be necessary to protect the slope from erosion. This may be as simple as planting trees or grasses, although large gradients will require cut and fill landscaping or retaining structures to prevent landslides.



**Lake Bunyonyi Secondary** Various slope stabilisation measures have been put in place to mitigate erosion and potential landslides

CASE STUDIES 5 11

# ENERGY GENERATION

Although some rural schools in East Africa have virtually zero energy needs, this is changing, with an increasing requirement for wireless routers, smart phones and computers. While electric lighting can be avoided during the day with strategic natural daylighting design, all schools require energy for cooking and water heating. Connecting to the national grid is a costly option for urban locations, with standby generators often being implemented during power cuts. For rural schools with limited budgets and increasing energy requirements, it is recommended to utilise smart energy saving principles and tried and tested appropriate technology applications.

## SOLAR PV

Photovoltaic panels are reducing in cost and small power uses for lighting, mobile phone and computer charging can easily be met by a local installation.

A photovoltaic (PV) system consists of solar panels, an inverter and batteries, which convert solar radiation into electricity. Solar panels should be positioned to maximise sunlight exposure. On the equator, sunlight is directly overhead, but panels should still be mounted at 15 degrees to ensure that they self-clean. It may be beneficial to mount panels facing east towards the morning sun as batteries can accept the most charge when they are at their lowest. A PV system can be used for charging phones or computers and provide lighting with energy-efficient light bulbs.

Item	Qty	Price (\$)	Total (\$)
NXT Batteries 200AH/12V	2	324.32	648.64
Inverter 800w/12V	1	297.30	297.30
Charge Controller	1	94.59	94.59
Solar Panel 150w	4	109.46	437.84
50mm battery cable	2m	9.46	18.92
50mm cable lugs	8	1.35	10.80
UV Cable 16mm	30m	2.16	64.80
Panel frames	1	37.84	37.84
Battery rack	1	48.65	48.65
Cabling	1	108.11	108.11
Sub Total			1767.49
Labour			176.75
Total			1944.24



Costing for a standard solar pv installation for a 50sqm classroom block with lighting, phone and laptop charging capabilities

CASE STUDIES

9 11

## SOLAR THERMAL

Solar energy can provide low cost hot water using anything from a black plastic pipe to glazed solar collectors.

Solar thermal technology or solar water heating uses free, renewable energy from the sun to warm water, using a solar thermal collector. At its most sophisticated, a solar collector is a type of solar panel containing tiny tubes of water that are heated by the sun. However, it is possible to create a collector using any material that conducts heat, such as a black hosepipe or a glass topped metal box. Heated water is piped to a storage tank via heat driven convection for use in the kitchen or WC facilities.



A professional solar thermal installation consisting of an evacuated tube solar water heater

CASE STUDIES

11

## FIREWOOD

Burning wood for cooking is an expensive and polluting use of energy. Carefully designed eco-stoves can reduce smoke inhalation and improve efficiency.

Generally, either eucalyptus or pine is used as fuel wood for cooking in schools. Unless part of a sustainably managed plantation, this can contribute towards deforestation and increase a school's operational carbon emissions. Cooking stoves are often inefficient and unsealed, allowing heat and dangerous gases to escape into unventilated kitchens. Eco-stoves reduce heat loss by burning timber in a sealed and insulated chamber, while channelling dangerous gases away from the user.



COF Primaries A well ventilated kitchen contains fuel-efficient hybrid eco-stoves with the ability to burn both biogas and firewood

CASE STUDIES

1 9

## BIOGAS

Biogas from a biodigester or bio-latrline system is a sustainable alternative to fuel wood that can also be used as a heat source for the school kitchen.

Biogas consists primarily of methane, which is produced through anaerobic decomposition of waste. Biogas can be produced from raw material such as manure, sewage and food waste, which are fermented in a closed system, known as a biodigester (see bio-latrline on page54). Biogas can be used in a gas engine to produce electricity but in schools the most appropriate application is for cooking fuel. A hybrid eco-stove is recommended, where a cast-iron gas hob is inserted into the traditional firewood-fuelled stove.



AWF Primaries The eco-stoves are fuelled with biogas supplied through a locally-made cast iron hob

CASE STUDIES

1 9

## BIOFUEL

New research has revealed cassava and banana peel as valuable raw materials that can be used as fuel instead of timber or charcoal.

There are currently various research streams into utilising agricultural and food waste in the production of biofuels and chemical additives. Cassava peel for instance has no mainstream use and its disposal can cause environmental issues. Research by BAM has been undertaken into potential uses for this waste, among which is the use of residual peels as fuel. Similarly, banana or matooke peelings can be converted into briquettes and used as an alternative to charcoal.



Green Bio Energy has engaged communities and taught them to make briquettes from waste matooke peel

CASE STUDIES



# WATER MANAGEMENT

Access to clean water is essential for children's survival and development. Increasingly water sources are under threat from contamination, which impacts not only on the health of children, but also on the social, environmental and economic development of communities. In rural areas of East Africa, one third of villages have no access to a valid water source. The main technology options are boreholes (44%), shallow wells (24%) and protected springs (21%). Tap stands, public kiosks and rainwater harvesting represent 11% of water sourced. Access to mains water supply is restricted to urban areas, where it is estimated 20% of premises have a safely managed water supply.

## RAINWATER HARVESTING

Schools often have a large roof catchment area for rainwater harvesting that can substantially augment a school's water requirements.

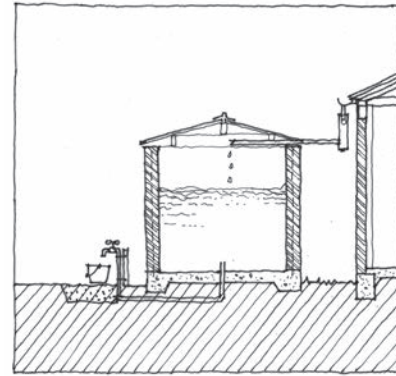

East Africa is an ideal location for rainwater harvesting as a primary source of clean water. Rainfall data and the available catchment area are required to determine available water supply. Demand is calculated based on the number of users and their average water consumption. If supply does not meet the demand then other sources of water will be required to meet the shortfall. Untreated rainwater can be used for irrigation and toilet flushing, but it must be treated for drinking and wash hand basin use.



**Nakapiririt VI** The new workshop is provided with four PVC water tanks to harvest water from the building

CASE STUDIES 4 6 9 11

## FIRST FLUSH DEVICE

A first flush device diverts the first rain away from the storage tank to keep stored water as clean as possible. First flush water can be used for irrigation.

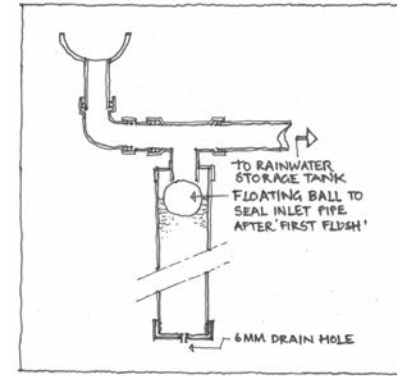

The first rain of a storm cleans the roof of dust and debris, which should be diverted before it enters the rainwater storage tank. A first flush diverter directs the first rainwater into a chamber, which contains a ball to stop the contaminated water from escaping. There is a valve or small hole at the bottom so that first flush water, which is often rich in organic matter, can be piped off for irrigation. As a general guideline first flush devices should remove approximately ten gallons (37.8) of water per 1,000sqft (92.9sqm) of roof/catchment area.



This rain filter diverts foul water through the down pipe using centrifugal force and filters clean water through a stainless steel screen

CASE STUDIES

## BOREHOLE WATER

In sites where connection to water mains is not feasible then a borehole could be a suitable solution to supplement rainwater harvesting.

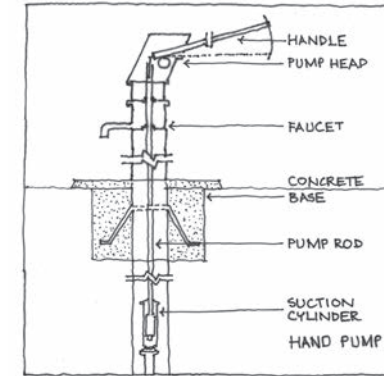

A borehole is a narrow hole made in the ground to allow for abstraction of groundwater, which is often quite pure especially when it has passed through fine granular soils. Boreholes can usually be relied upon for year round water supply. They should be sited at least 30m away from pit latrines or other sources of contamination. Water is extracted using a manual or motorised pump, which may be solar-powered to reduce on-site energy demand. Extracted water may be stored in tanks to reduce continual operation of the pump.



Good Future and Hope have installed a solar-powered borehole and 10,000L storage tank at their orphanage in Nakisunga, Uganda

CASE STUDIES 4 9

## FILTERING SYSTEMS

Raw water no matter what its source should be treated in a point-of-use filtering system to ensure safe drinking quality water.

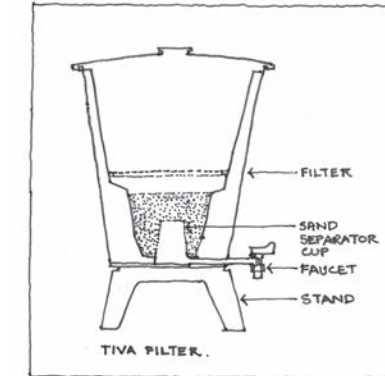

Raw water should be filtered, treated or boiled before drinking. Even after treatment water quality may be compromised through unsafe handling and storage. For this reason, point-of-use filtering systems are the preferred option for schools. Biosand filters are slow sand filters that offer a low energy alternative to water boiling. Concrete biosand filters can be made locally. Plastic biosand filters such as the Tiva water filter are an increasingly common and affordable option in schools, costing \$81 with a capacity of 40L per day. The Advanced Tiva water filter uses sand, a carbon membrane filter and UV treatment to process 6,000L per day at a capital cost of \$5,000.



A typical plastic biosand filter, shown here at Kyere Primary School, Uganda, is the most common and affordable option for schools

CASE STUDIES

## WATER, SANITATION & HYGIENE

Access to adequate water, sanitation and hygiene facilities reduces illness and death, as well as improving physical and cognitive development.

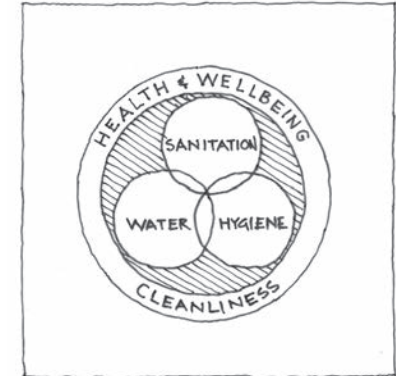

Water-related illnesses are a main cause of absenteeism in schools, while worm infestations, of which 100% are attributed to poor sanitation and hygiene, have been found to result in a tangible loss of IQ. To combat this, it is imperative that schools provide clean drinking water, well maintained hand washing stations, gendered bathrooms and adequate facilities for girls to manage their menstruation. Water, sanitation and hygiene (WASH) lessons on good hygiene practices should be incorporated into the school curriculum.



ECD&F Centres have child friendly hand wash stations outside each of the latrines to encourage good hygiene practices

CASE STUDIES 6

# WATER STORAGE

Water storage is essential for areas where there is no supply infrastructure or there is unreliable availability. It is cost effective where water needs to be purchased. The NWSC bills 0.96 USD per 1,000L of water for institutions. This price is higher in rural locations where water is collected and transported from public stand taps at 0.14-0.27 USD for a 20L jerry can. A typical classroom block without an alternative water supply requires 25,000-30,000L of water storage, while two classroom blocks require in the region of 40,000-50,000L. This capacity can be contained in a single big tank or in multiple smaller tanks, depending on preference.

## CORRUGATED IRON

Tanks built of curved corrugated iron sheets welded into cylindrical tanks are the cheapest but least durable water storage option.

- Capacity – 2,000L-15,000L
- Life span – 7years
- Cost (10,000L) - \$550

Corrugated iron tanks were one of the earliest rainwater storage options available and continue to be cheaper than any alternative. They are generally not sold at hardware stores, but at specialized metalworks where fabricators weld 24 or 26 gauge iron sheets together to form cylindrical water tanks. The tanks rust quite quickly and can only be expected to last in the region of 7 years. They are far more common in households than in schools, as institutions generally opt for greater durability.



A corrugated iron water tank showing signs of rust

CASE STUDIES

## STAINLESS STEEL

Stainless steel tanks are by far the most expensive option but are rust and corrosion resistant and durability may result in cost savings in the long run.

- Capacity – 750L-500,000L
- Life span – 50years
- Cost (10,000L) - \$2,200

The most expensive water storage option: stainless steel tanks are more durable than any alternative, which can result in cost savings in the long-run. They are quick to install and more robust to receive plumbing than plastic tanks. Furthermore, stainless steel is unaffected by intense heat conditions and does not support the growth of bacteria or algae, making it a hygienic option for water storage. It is also recyclable in nature, so is arguably one of the more eco-friendly options.



NTC Kaliro A new steel tower structure houses an 100,000L steel water tank supplied by an on-site borehole

CASE STUDIES

4

## PLASTIC

Plastic water tanks are the most common water storage option for schools. They have decent durability but can be vulnerable to vandalism.

- Capacity – 100L-24,000L
- Life span – 20years
- Cost (10,000L) - \$1,300

In many ways plastic tanks are the standard solution although they are relatively expensive and limited in capacity to around 24,000L. They are often organised in multiple tank systems, and should be placed at the same level and interconnected via underground pipes so that they function as one big tank. Plastic tanks are vulnerable to vandalism and can also become damaged through prolonged exposure to UV. They can require the construction of a protective brick wall, or shading elements, such as bamboo or planted screening, which further pushes up cost.



NTC Kaliro Two large plastic tanks at the end of each of the buildings are screened with bamboo to protect them from sunlight

CASE STUDIES

4 9 11

## UNDERGROUND

Underground water tanks are often a preferred option as they can be constructed from local materials, are cost effective, secure and discreet.

- Capacity – 5,000L-200,000L
- Life span - 25years
- Cost (10,000L) - \$1050

Underground water tanks offer a discreet and space-saving storage solution. The surrounding earth creates external resistance to water pressure, which means that costly reinforcement can be reduced. Tanks may be rectilinear or domed with a reinforced concrete slab. A masonry structure, usually fired brick is finished with a waterproof cement plaster. The exterior is painted with bituminous paint. Water must be fetched via a pump, which may be manually operated, fuel, mains or solar powered. An access point for the pump is all that is visible above ground.



ECD&F Centres A 35000L underground rainwater tank provides water for the greater community's daily use

CASE STUDIES

6

## ISSB

Interlocking stabilized soil blocks offer a low cost, but labour intensive solution to water storage. ISSB tanks are well protected against damage and theft.

- Capacity – 5,000L-200,000L
- Life span – 15years
- Cost (10,000L) - \$990

ISSB tanks are extremely versatile and can be built above or below ground in a wide range of sizes from 5,000L-200,000L capacity. Smaller tanks require a specialist press that produces a curved ISSB block, whereas large tank sizes can be produced with regular straight blocks. No reinforcement is required for tanks of 50,000L or less. Above this a double ISSB wall is recommended, consisting of two concentric circles with cement mortar packed between them. ISSB tanks are cost effective and environmentally friendly, but are labour intensive to construct.



A large ISSB water tank consisting of two concentric circles of standard ISSB for additional reinforcement

CASE STUDIES

11

# WASTE MANAGEMENT

Most rural communities in East Africa do not generate a lot of waste, and over 80% is organic material. Any inorganic waste produced is generally burnt. In urban areas there is a waste collection service that is ultimately disposed of at a landfill. In some cities, such as Kampala, this service is provided by the private sector, with fees being administered for collection and transportation. For many schools this is a costly and unsustainable solution. Efforts should be made as far as possible to minimise waste production and ensure that waste disposal is hygienic, safe and sustainable. With some creative thinking it is possible to turn rubbish into a resource.

## THE WASTE HIERARCHY

The waste hierarchy indicates an order of preference to reduce and manage waste. The aim is to extract the maximum benefit from products while generating the minimum amount of waste.

Waste management strategies in order of preference are prevention, reduction, reuse, recycling, incineration and disposal to landfill. Preventing or reducing the production of waste is achieved through making smart consumer choices to avoid single use products and excessive packaging. Reuse is prolonging the usable life of a product through selling, donating or upcycling items which are no longer needed. Recycling is the breaking down of a product into something entirely new, a local example being the blending of plastic waste with sand and aggregate to make pavers.



The Appropriate Technology Centre has constructed a toilet block out of recycled plastic bottles

CASE STUDIES

## ORGANIC WASTE

Under aerobic conditions, organic waste such as kitchen scraps or plant material can be recycled into a nutrient rich fertiliser called compost.

Composting is an aerobic method of recycling organic material otherwise regarded as waste, to produce a soil conditioner or compost. At its most simple, composting involves disposing of organic waste in a pit and turning the waste periodically with a spade to keep it aerated. Earthworms may be added to further aid aeration and speed up the composting process. It is essential that waste is properly segregated to avoid compost becoming contaminated with plastic or glass.



Nakapiripirit VI 'Life Projects' teach students how to manage agricultural land including how to compost organic waste

CASE STUDIES

11

## HAZARDOUS WASTE

Clinical or hazardous waste, such as sanitary pads should be disposed of via incineration to avoid the spread of harmful pathogens.

Incineration is a hygienically safe waste treatment process for hazardous materials such as hospital waste and sanitary products. Hazardous waste should be incinerated at very high temperatures of at least 850°C to ensure pathogens are destroyed without causing excessive pollution through incomplete combustion. The incineration by-product is ash which should be disposed of in a lined ash pit. The construction of incinerators at schools is an essential feature of schools' sanitation and hygiene management.



COF Primaries An incinerator is located next to the toilet block to deal with potentially hazardous sanitary waste

CASE STUDIES

1

## GREY WATER RECYCLING

Grey water from hand washing and showering can be separated at source and either treated and stored or diverted directly for simple drip irrigation.

Waste water from wash hand basins or showers is not as contaminated as black water from toilets or kitchen sinks. This grey water can be diverted for treatment through reed beds, UV or carbon filtration. Treated water can be used for flushing toilets, washing clothes or watering plants. Alternatively, grey water can be diverted in a direct use system for immediate drip irrigation. Grey water recycling significantly reduces water consumption, particularly where there are water flush toilets in place.



Grey water can be poured directly into a grey water tower for the safe irrigation of fruit and vegetables

CASE STUDIES

## DRAINAGE

Surface water drainage channels should be constructed to divert storm water that collects as a result of local rainfall.

East Africa experiences heavy and sustained rainfall at various periods throughout the year. Drainage channels should be built to divert this excess water to existing municipal storm water drains where present. Open channels are preferable to make them easier to clean. In order to limit the volume of surface runoff generated, hard surfaces should be limited and grass should be planted to aid infiltration of some of the would-be surface runoff.

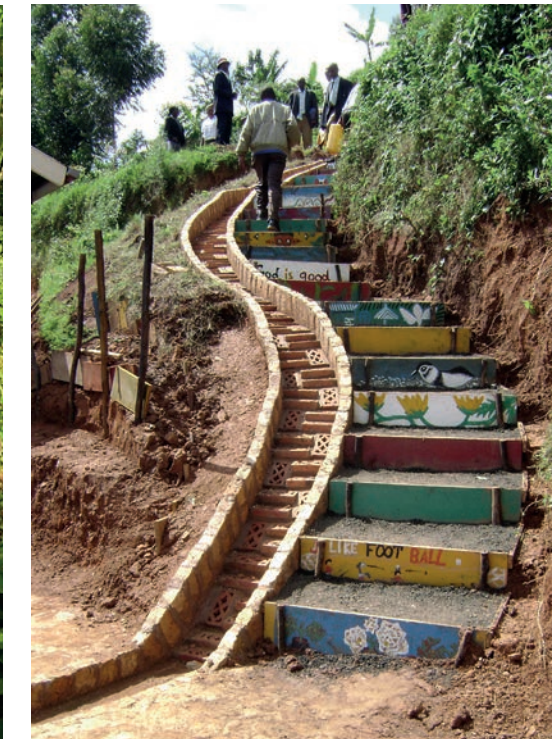

Lake Bunyonyi Secondary An open channel storm drain incorporates rough textured bricks to slow the flow of the water

CASE STUDIES

4

5

# HUMAN WASTE

Outside of cities and large towns there is no access to any form of waste water treatment, and even within cities sewerage coverage is extremely limited, in Kampala at less than 10%. Pit latrines are consequently the default sanitation option in East Africa, essentially a large pit dug in the ground and covered with a floor slab that contains a hole to accept human waste. Improvements can be made to facilitate cleaning such as embedding a ceramic squatting toilet pan or plastic saTo pan. When the pit is full, it is usually sealed over and the area is rendered unusable. There are several preferred sanitation options to consider. Sanitation blocks should be built away from other accommodation and functional spaces to minimise smell and insect nuisance.

For more information see:

<https://oxfamlibrary.openrepository.com/bitstream/handle/10546/620687/gd-tiger-worm-toilet-manual-280319-en.pdf>

## VENTILATED IMPROVED PIT LATRINE ECOSAN TOILET

Adding a ventilation pipe to a pit latrine can eliminate odours and aid fly control. Lining a pit latrine ensures it can be mechanically emptied and reused.

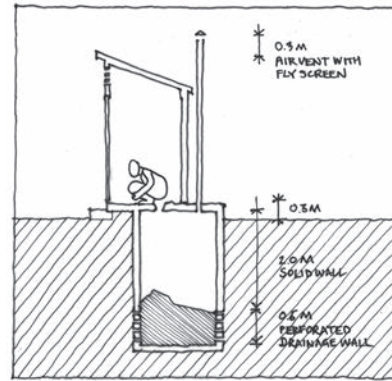

Ventilated Improved Latrines have a vertical vent pipe directly over the pit. Wind that passes over the pipe causes air to escape, creating a downward draught through the drop hole. This effectively channels odours away from the user. The vent pipe also aids fly control as flies are prevented from leaving through a fly screen at the top. The pit is lined so that solid waste can be emptied when required. A school requires a pit with a volume of 6000L for every 100 children, provided it is emptied once a year.



**Lake Bunyonyi Secondary** Temporary latrines have been replaced with two permanent four-stance latrine blocks

CASE STUDIES

Ecological sanitation principally involves separating out urine from solid waste (urine diversion) and recycling both for use as fertiliser.

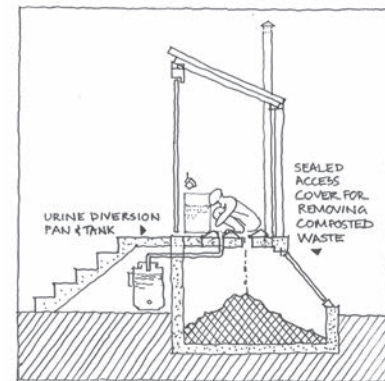

Ecological sanitation or ecosan toilets require user training and a toilet bowl which collects the urine and diverts it to a holding tank or soakaway. Fecal matter is collected in a separate chamber and usually combined with layers of ash or sawdust to keep the composting chamber dry. Constructing the toilet cubicles in pairs allows one to be in use while the other goes through a composting cycle of 6 months before it can be emptied and used as fertiliser. Ecosan toilets reduce the risk of underground water contamination and have a lower lifetime maintenance cost than an equivalent pit latrine system.



**ECD&F Centres** use ecological sanitation technology to improve hygiene and comfort by reducing smell and sealing from flies

CASE STUDIES

## VERMIFILTER TOILET

The vermifilter toilet is a cheap and low maintenance composting toilet system, which uses tiger worms to create a rich and odour-free fertiliser.

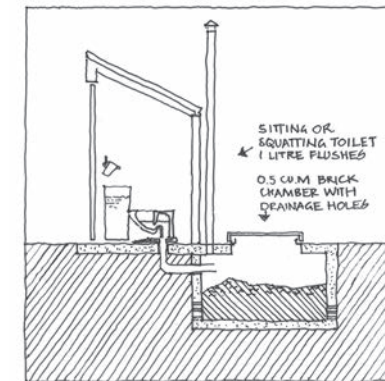

Vermifilter toilets or 'Tiger Worm Toilets' use tiger worms to speed up the composting process reducing sludge build-up by up to 80%. This removes the need for traditional desludging as the vermicompost is simpler to remove, saving in the long term on operation and maintenance costs. The system does not require a special toilet bowl for urine diversion, instead operating as a pour flush latrine, where a small amount of water reduces the urine acidity. In Uganda, testing is being undertaken by the Appropriate Technology Centre and Water for People.



The Appropriate Technology Centre has set up a wormery to supply worms for their Tiger Worm Toilets

CASE STUDIES

## BIO-LATRINE

A bio-latrine is a low maintenance system comprising of a toilet and simple biodigester unit that turns human waste into fuel and fertiliser.

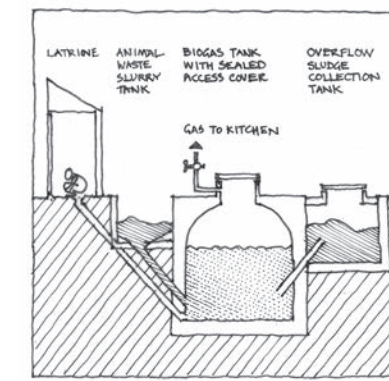

A bio-latrine can be constructed using local materials, and requires no water or additional input other than human waste. Faeces are fed via a pipe into the biodigester chamber, which is normally constructed of bricks in a cylindrical or fixed dome design to minimise gas leakage. As faeces are broken down through anaerobic digestion, methane gas collects in the upper part of the chamber and passes through an outlet pipe, either to a storage facility or directly to where it is required (see page 46). The remaining slurry/biodegraded waste is an ideal organic fertiliser.



**COF Primaries** Toilets have an integrated biodigester that supplies the school kitchen with free cooking gas

CASE STUDIES

## WATER-BASED SYSTEM

Water flush systems require substantial amounts of water. To deal with water-based waste a complex settlement tank and soakaway system is required.

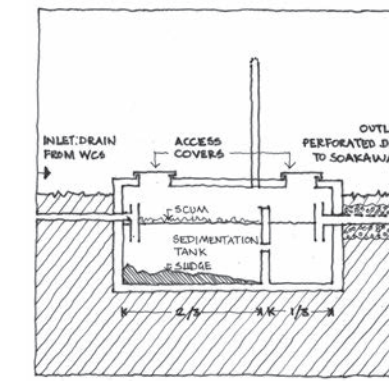

Water based systems are common in cities with water supply and centralised drainage. In rural areas, a septic tank is required to receive both the black water from toilets and grey water from showers. A septic system consists of a plastic or concrete underground settlement chamber that flows into a soakaway system. The soakaway is a leach field of perforated pipes in a gravel bed to allow water to drain away. The tank should be sized to approximately 20,000L for every 100 children. A dual flush system should be utilised to reduce water demand, which can be supplemented through grey water recycling.



A typical underground concrete settlement chamber

CASE STUDIES

1



# 5 CASE STUDIES

# 1 COF OUTREACH VILLAGE SCHOOLS

Location	Villages in Rakai and Lwengo
Architect	Studio FH Architects
Client	Cotton On Foundation
Consultant	The Landscape Studio (Landscape) Aquila Gallery (Structural Engineers) Equatorsun (Services & AT Engineers) Dudley Kadibante and Partners (QS)
Size	Approx. 1500m <sup>2</sup>
Cost	\$440/sqm (excl. VAT)
Year	2015-2020

In late 2013, Studio FH Architects were approached by the Cotton On Foundation to develop a set of typical primary school building designs that can be constructed on various sites with differing environmental conditions. Each school accommodates 500 students and ten teachers, the latter residing on site. Seven of these schools have been completed to date, three are under construction, and a further twenty or so are to follow.

The need for buildings that are adaptable to many different sites called for designs that are largely independent of their orientation towards the sun. This consideration led to a classroom block module with covered walkways on all four sides. Cement screed floors, fair-faced clay brick and glassless window shutters were selected for their outstanding behaviour over time; particularly the yellowish multi-coloured clay bricks, which virtually don't age despite the either dusty or muddy environments they find themselves in. The simplest of passive design principles form the basis of the classroom design; reflective roofing material, shading of all windows, good cross and stack ventilation.



SHADING  
VENTILATION  
DAYLIGHT

ENERGY

WASTE

## GENERAL ARRANGEMENT

The school consists of five main classroom blocks, with toilets, a kitchen block and teachers' accommodation on the peripheries. The classroom blocks have large windows, built-in shelving, bare floors and a chalkboard at one end.

In the absence of a formal dining or assembly hall due to budget considerations, one of the classroom blocks features a multipurpose space with a lowered circular seating area located in between two classrooms. Both adjacent classrooms have full-width pivoting and sliding panel doors which, when opened, create an enlarged assembly space for the school community. When closed, the doors act as blackboards for an informal covered external teaching or activity space.

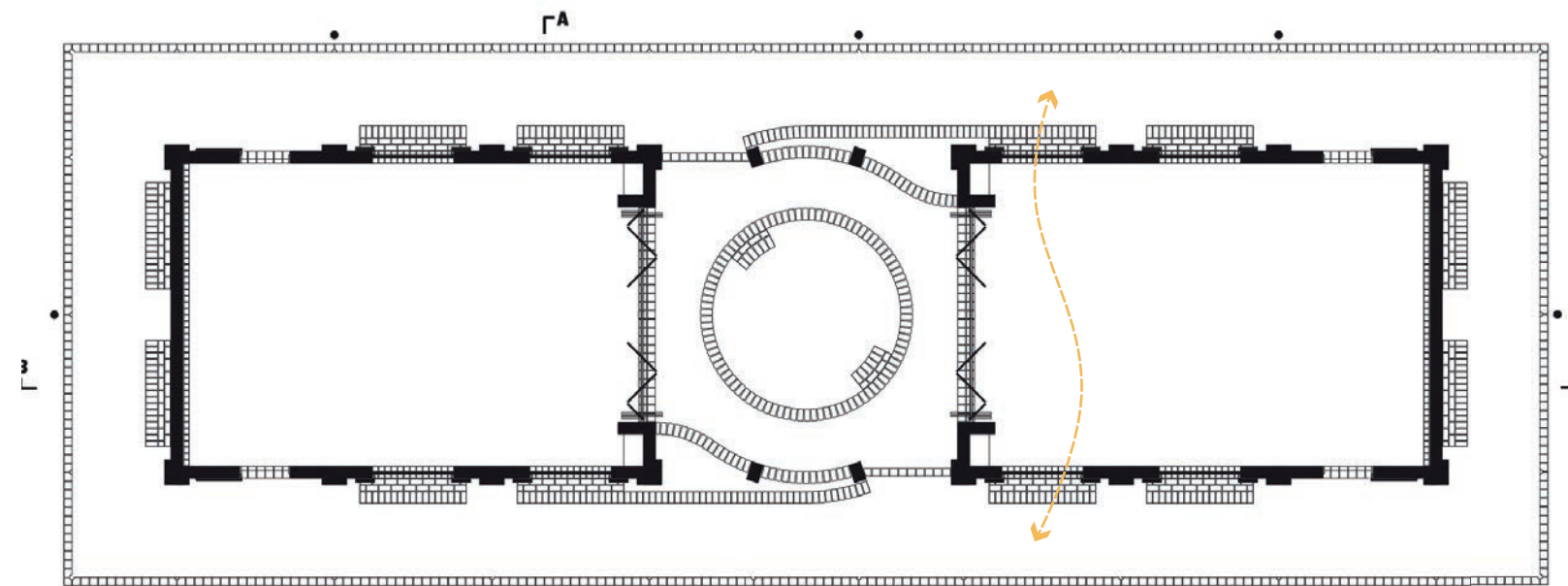

classroom floor plan

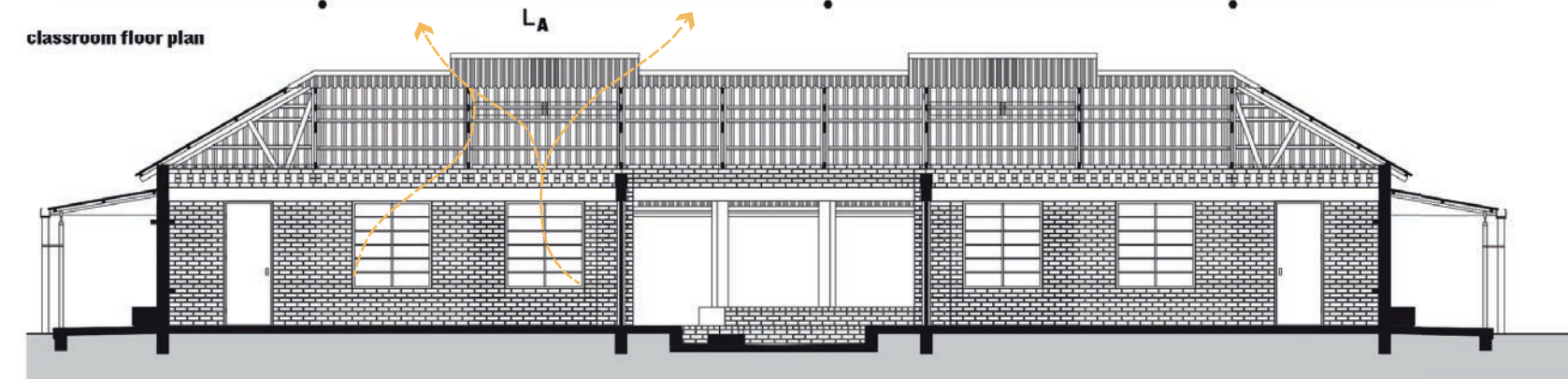

section BB

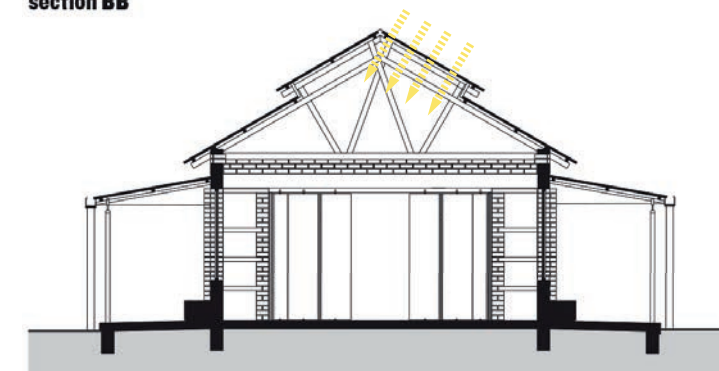

section AA



SHADING  
VENTILATION  
DAYLIGHT  
ENERGY  
WASTE

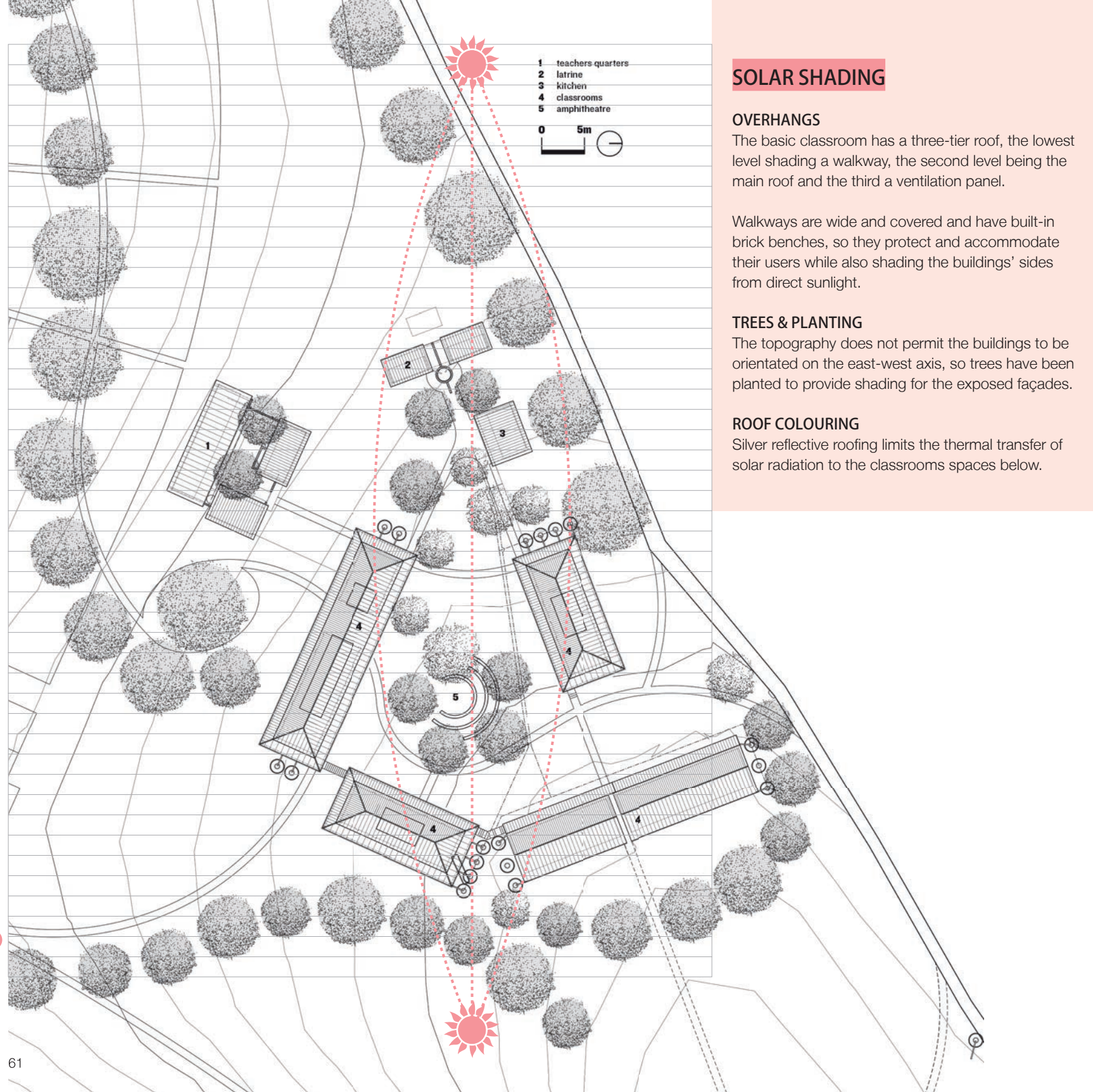

## SOLAR SHADING

### OVERHANGS

The basic classroom has a three-tier roof, the lowest level shading a walkway, the second level being the main roof and the third a ventilation panel.

Walkways are wide and covered and have built-in brick benches, so they protect and accommodate their users while also shading the buildings' sides from direct sunlight.

### TREES & PLANTING

The topography does not permit the buildings to be orientated on the east-west axis, so trees have been planted to provide shading for the exposed façades.

### ROOF COLOURING

Silver reflective roofing limits the thermal transfer of solar radiation to the classrooms spaces below.

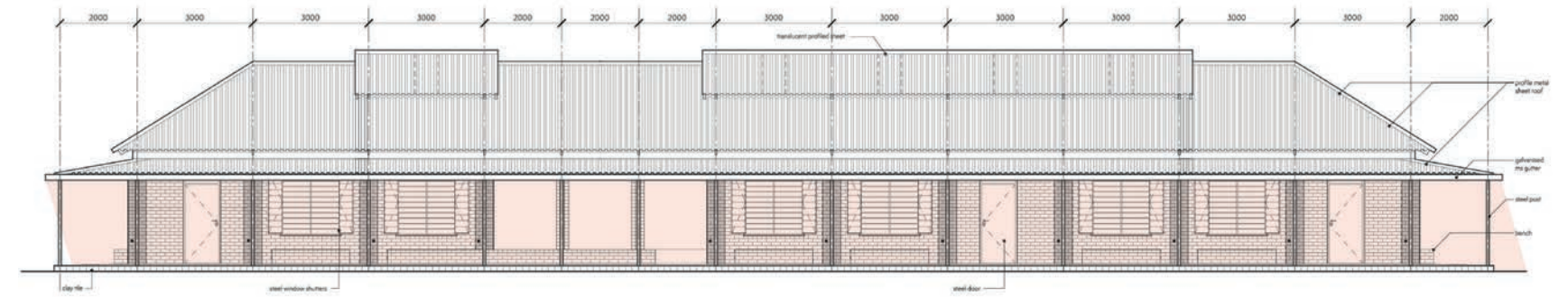





## NATURAL DAYLIGHT

### EVEN DISTRIBUTION

Windows are uniformly spaced along both sides of the classroom block to allow an even distribution of daylight in, while excess heat is free to escape.

### DAYLIGHT CONTROL

All windows are fitted with operable shutters that can be opened or closed to control the quantity of light according to preference.

### ROOFLIGHTING

Daylight provision is enhanced by roofsheet perforations in selected areas of the vent roofs; this feature allows for a well-lit learning environment even in stormy conditions when the steel-timber shutters have to be closed as a protective measure against wind and driving rain.



## PASSIVE VENTILATION

### OPENINGS

High level perforations create additional openings for heat to escape through night flushing.

### CROSS VENTILATION

There is good passive ventilation due to shallow building depths and upwards movement of air owing to the elevated vent roofs.

KITCHEN BLOCK CONTAINING HYBRID ECOSTOVES



## ENERGY GENERATION

### BIOGAS

Fuel efficient hybrid cooking stoves can utilise both gas from the biodigester toilets and traditional timber fuel if required. The kitchen block itself is well ventilated to ensure adequate health and comfort conditions.

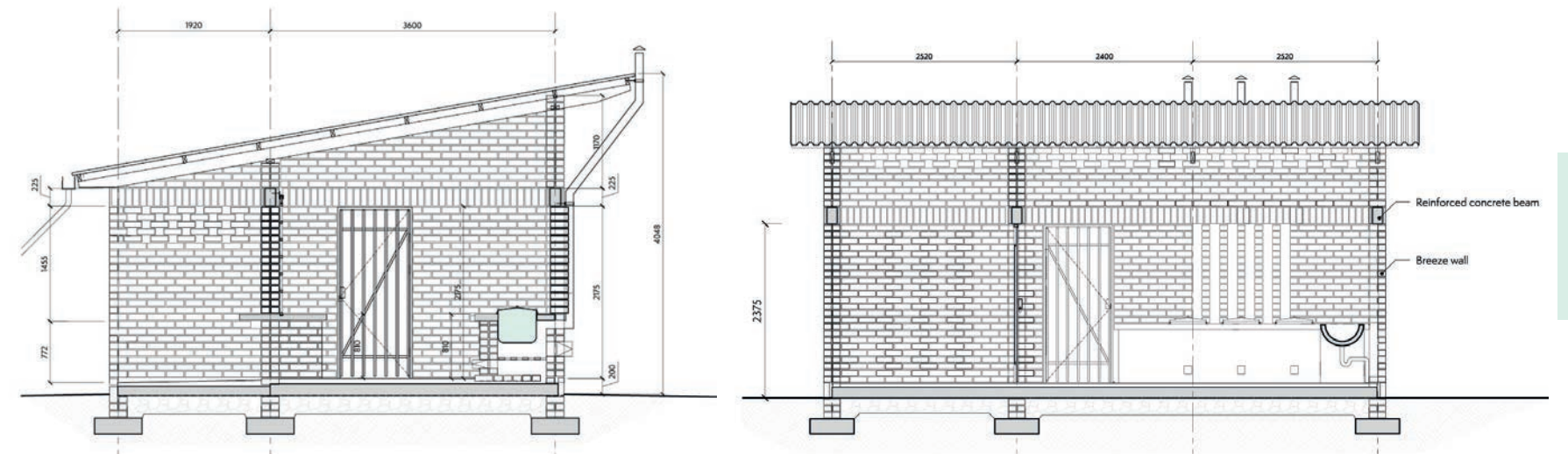
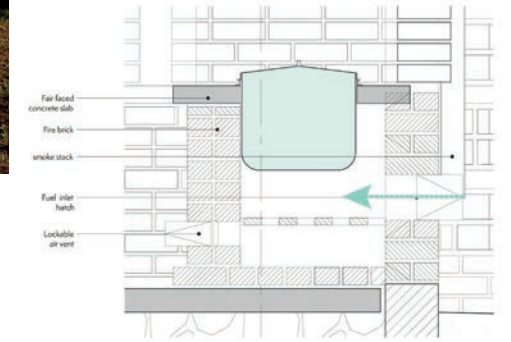

SHADING  
VENTILATION  
DAYLIGHT

ENERGY

WASTE

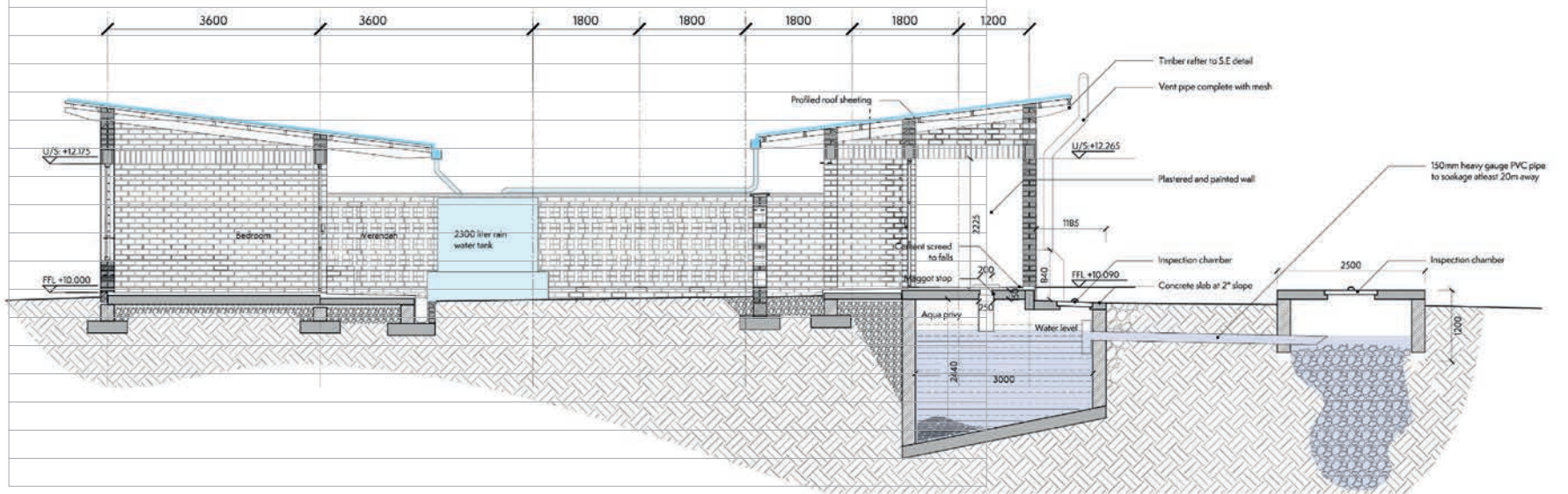
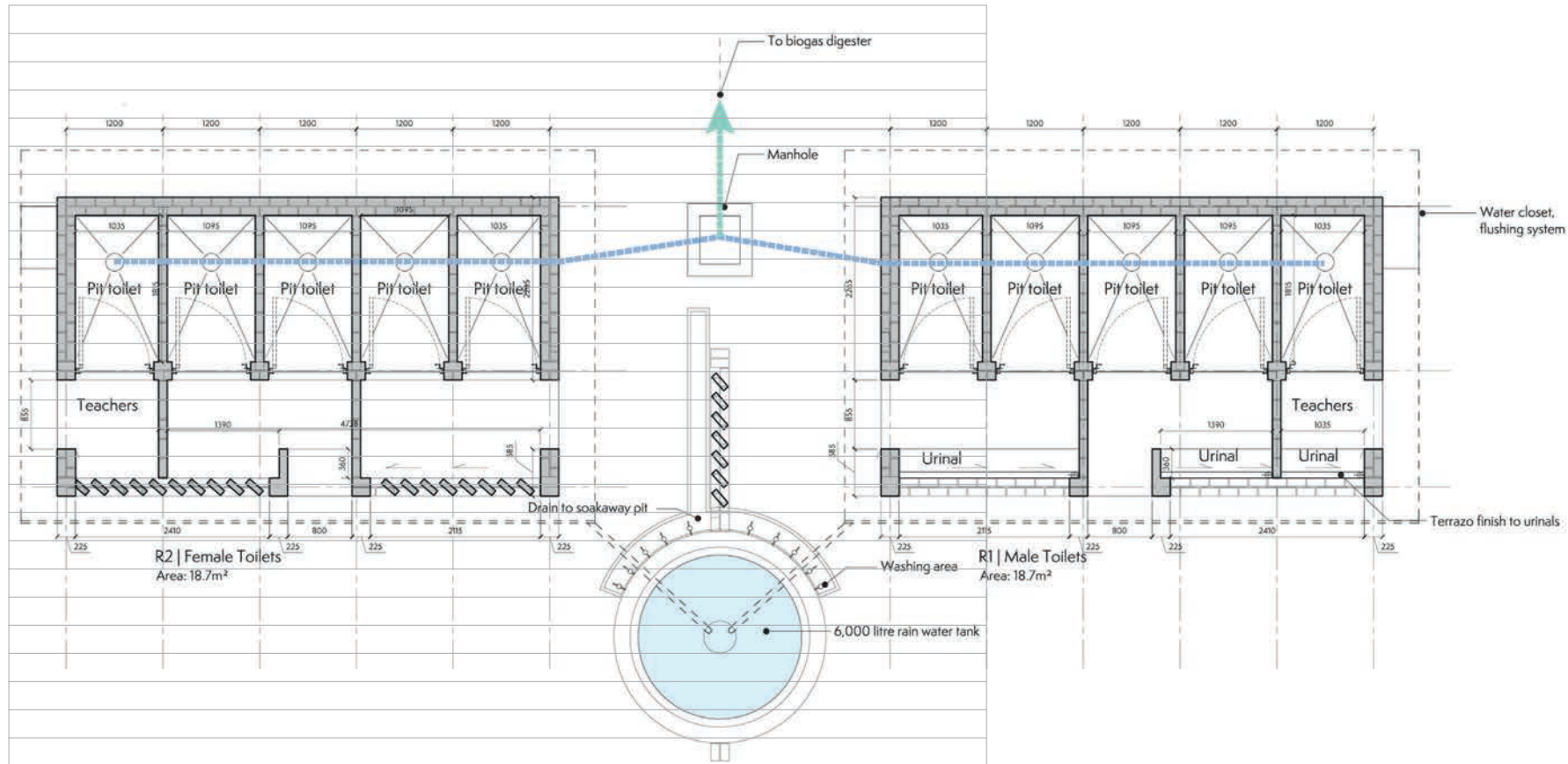

## WASTE MANAGEMENT

### BIO-LATRINE

Pupil washrooms are a stand-alone brick structure, which conceals an integrated biodigester that supplies the kitchen with free cooking gas.

### AQUA-PRIVY

The teacher block has been fitted with an aqua-privy; a water-based system where the toilet stands directly on top of a septic tank. The advantage of an aqua-privy is that it doesn't require a conventional water-borne toilet system, yet is smell-free and much cleaner than a conventional latrine. The septic tank is filled with water which is gently replenished with grey water from the handwashing sinks.

### HAZARDOUS WASTE

A brick incinerator is located near to the girls toilets for efficient disposal of sanitary products.



UNDERGROUND BIODIGESTOR

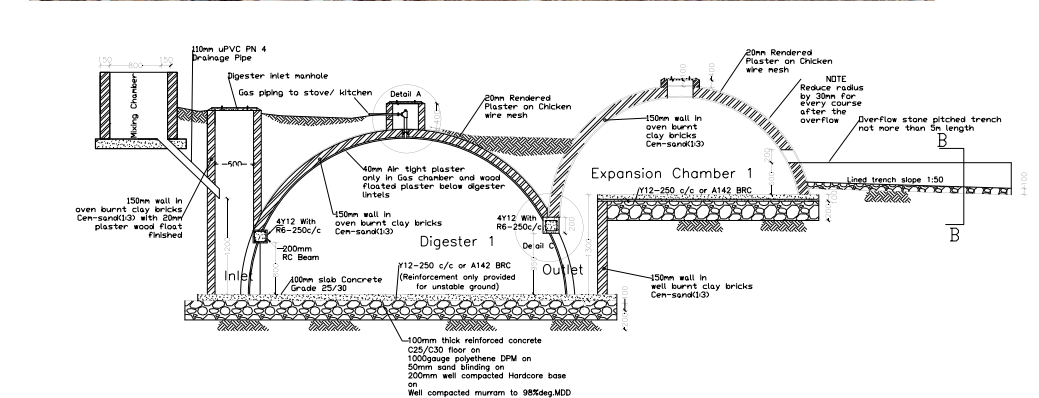

STUDENT TOILET BLOCK AND INCINERATOR

# 2 RUGERERO HEALTH CENTRE

Location	Rugerero Sector, Rubavu District, Rwanda
Architect	ASA Studio
Client	Health Builders + Rubavu District
Consultant	-
Size	2800sqm (building) 5600sqm (plot)
Cost	\$154/sqm inc. VAT (building) \$88/sqm inc. VAT (total)
Year	2017-2018

ASA studio has designed an improved health centre in Rugerero, which formerly had limited access to basic life-saving health services. The new facility is designed to serve approximately 45,000 people living in the Rugerero Sector and surrounding rural areas in west Rwanda. The project was initiated by Health Builders and partially financed by the local government. The collective ambition was to provide a high quality health facility, which engaged the community through participatory design and construction, and utilised locally sourced materials and traditional techniques.

The single storey building is made from on-site fired bricks reinforced with metal bars and buttresses that rest on volcanic stone foundations. ASA focused on enriching the aesthetic impact of the design to make the health centre more appealing to its users. The spatial sequence is intuitive and visually uniform to facilitate movement and orientation through the building. Universal accessibility is ensured through ramps and smooth surfaces. Light, exterior views and quality materials enhance the healing process and create a peaceful and pleasant working environment.



## GENERAL ARRANGEMENT

The design is based on simple considerations of accessibility and strategic separation of outpatients, inpatients, mothers and visitors. The programme is arranged into two main blocks connected by a central corridor. The entry block hosts reception and waiting areas, OPD, nutrition and administration. The upper block hosts the wards and maternity unit. The latter is accessible by ambulance through a dedicated gate. A separate service block consists of incinerator, generator, storage and water treatment. Landscaping and seating areas characterize the green filter space between the blocks. This common area offers shade and seating to mothers and visiting families.



## SUSTAINABLE LANDSCAPE

The landscaping defines three grades of privacy: the public frontage of the health centre, which spills out onto an existing square; a semi-private internal courtyard with shaded seating for visiting families and a private garden to the rear.

## CLIMATE COOLING

These green patios throughout the building contain numerous trees and shrubs to reduce local temperatures through evaporative cooling, as well as having a positive healing effect on patients.



## PARTICIPATORY PROCESS

### CAPACITY BUILDING

Masons, carpenters and welders were educated through hands-on training to improve local construction techniques. This has a spillover effect on the quality of local construction, resulting in a more dignified, healthy and safe built environment.

### EMPOWERMENT

ASA are working to promote gender equality in the male dominated construction industry, which on the African continent comprises of less than 6% women. Construction of the Rugerero Health Centre was undertaken by a 50% women workforce, who benefited from employment and training, enabling them to earn as they learn. With their wages, women were able to provide a health-insurance plan and two to three meals a day for their families.





UMUSAVE WOODEN PLANK CEILING



## NATURAL DAYLIGHT

Daylight is an important resource in consultation rooms, wards and the delivery area to reduce expensive power consumption and overcome frequent power cuts.

### EVEN DISTRIBUTION

The plan of the health centre has multiple cut outs, which act as light wells allowing daylight to penetrate in to the internal spaces. Maximum daylighting is achieved through the prevalent use of feature windows, wall perforations and rooflights.

### ROOFLIGHTING

The rooflight design has been carefully considered to reduce glare. Openings are not cut out of the roof itself, but allow light to enter above the roof and penetrate into the spaces below by reflecting off the white plaster walls.

### DAYLIGHT CONTROL

Direct light is reduced through the use of shading devices and woven screening.

## SOLAR SHADING

### OVERHANGS

Large overhangs create a colonnade around the central courtyard, which keeps direct sunlight off the masonry walls. A covered walkway traverses the courtyard to create a shaded connection between the two accommodation blocks.

### DOUBLE SKIN ROOF

Umusave wooden planks with damp proof and insect preservative have been used as a ceiling material. These are attached to wooden purlins on the underside of the steel roof trusses, creating a substantial air gap that helps to limit thermal transfer from the metal roof sheets.

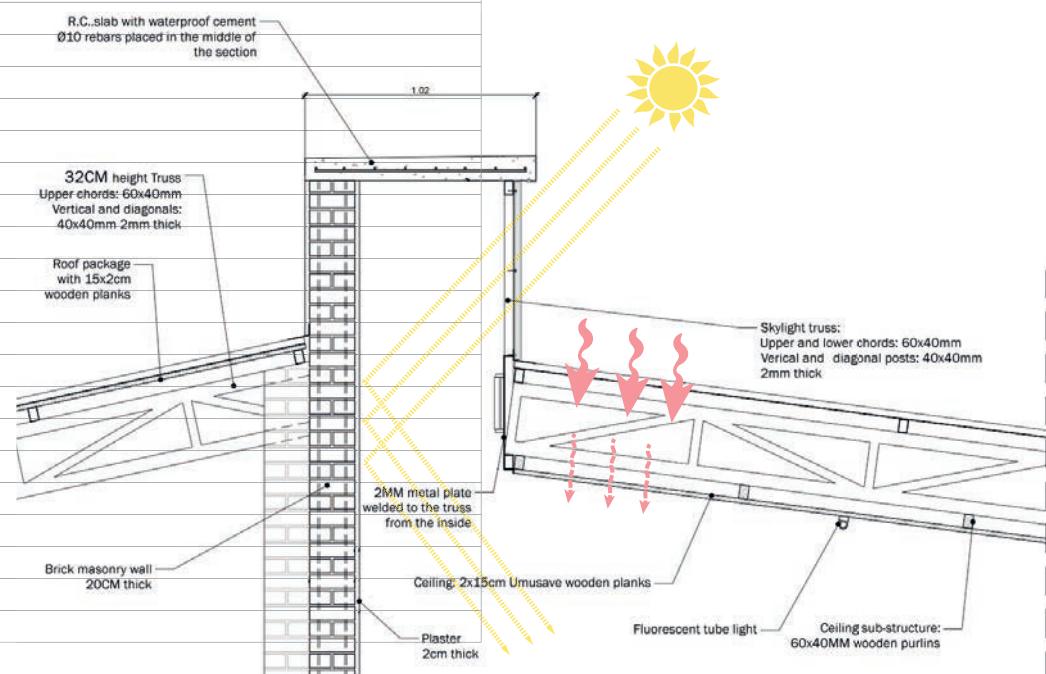

ROOFLIGHT DETAIL

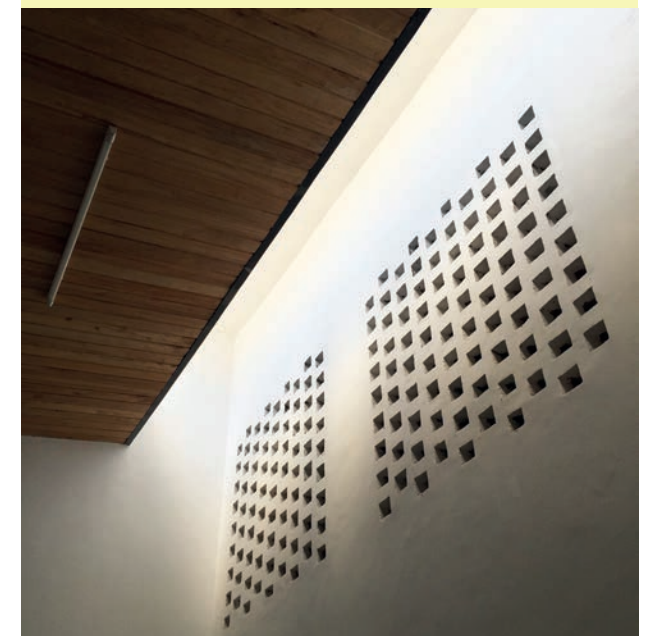
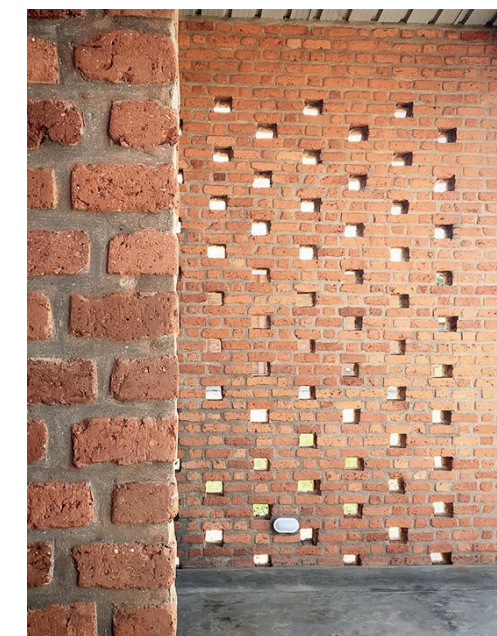

# 3 ILIMA PRIMARY SCHOOL

Location	Ilima, Democratic Republic of the Congo
Architect	MASS Design Group
Client	African Wildlife Foundation
Consultant	Arup Engineers
Size	800sqm (building) 1100sqm (plot)
Cost	-
Year	2015

In 2012, MASS Design Group and the African Wildlife Foundation (AWF) partnered to implement the Classroom Africa Initiative, a network of conservation schools throughout Africa engineered to mitigate conflicts between people and wildlife and facilitate environmental stewardship. The Ilima Primary School was the first school created by this collaboration (see also page 133).

Ilima is located deep in the jungle of the Congo Basin, six hours by motorcycle from the nearest airstrip. The school serves as a community centre for village-level programming to promote sustainable farming and hunting practices for the mutually beneficial integration of villagers and wildlife. With its innovative design, it is the largest and most complex structure many of the villagers have ever seen. The redesigned classrooms, with capacity of 350 (replacing an old lean-to on this site with room for 90) shelter students from the elements and invite focus and curiosity, leading to higher student attendance and retention rates. Ilima Primary School is a building with virtually zero embodied energy, designed for extreme sustainability, redefining what architecture can aspire to in limited-resource areas.



## GENERAL ARRANGEMENT

For the design, the architects staked out two circles, one for a demonstration and conservation garden, the other for a play area. The school building—two arcs that face away from each other—sits between the two circles. The southern arc contains three classrooms and a library; the northern arc houses three classrooms and an administration space. A suspended canopy roof connects the two wings. Classroom doors are staggered and face an interior hallway as well as the exterior of the building—a strategy that distributes wear and tear on topsoil.

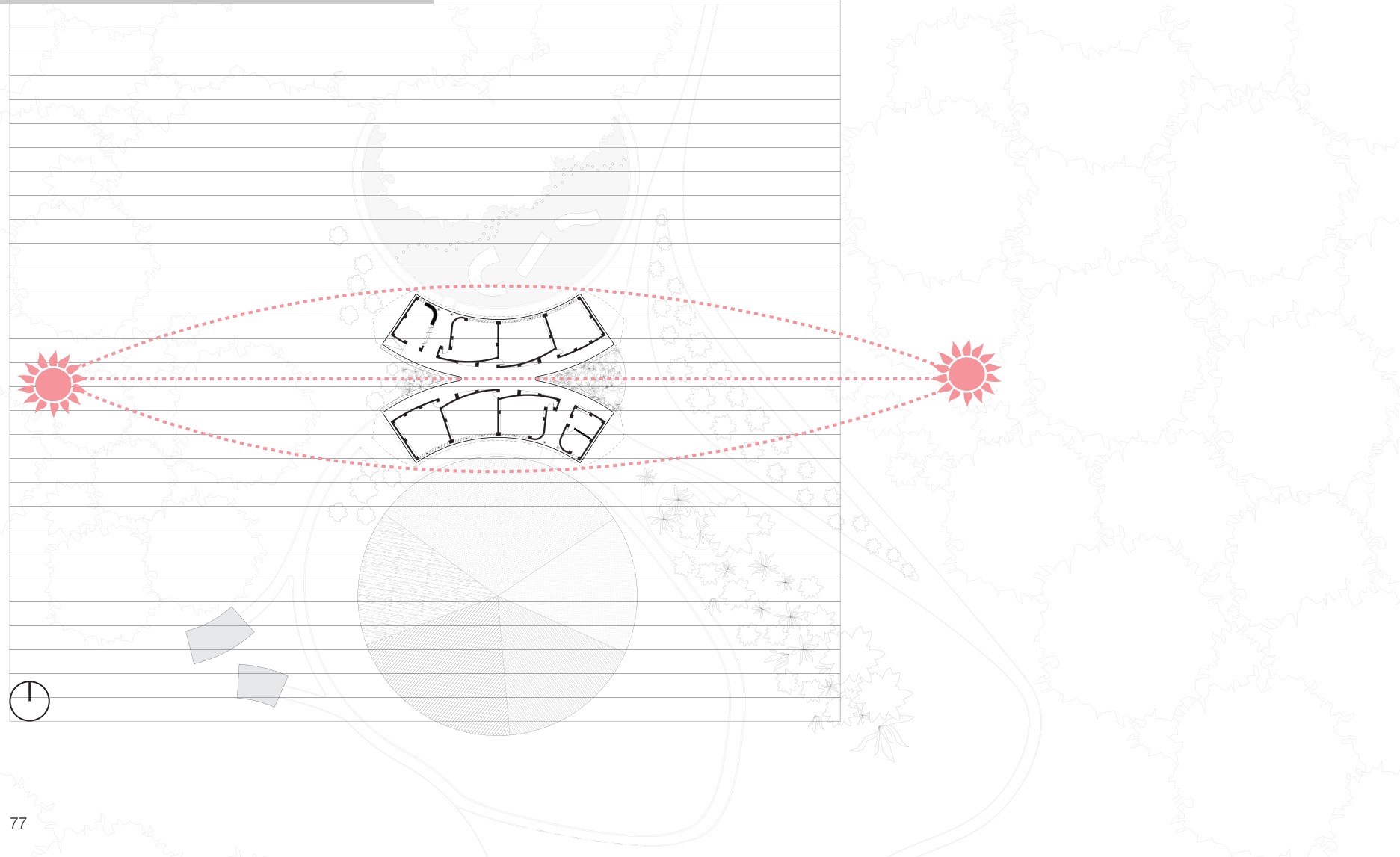





## PARTICIPATORY PROCESS

### IMPACT DESIGN METHODOLOGY

The project was initiated by the AWF who offered to provide a “conservation school” if the Ilima community promised to protect 600,000 acres of rainforest from hunting, logging, and agriculture. These problems stem, in part, from poverty and lack of access to education, so it was clear from the beginning that a new school building would have a positive impact. MASS designed the school with a view that the architecture should amplify AWF’s conservation efforts.

### COMMUNITY ENGAGEMENT

MASS’s design practice hinges on thorough community engagement at every phase of design and construction, beginning projects with a process of pre-design immersion and working with future occupants to identify unique constraints and local opportunities. Forums were held with community leaders, residents, teachers, and students through all steps of design and construction in order to create a finished product with, not for, the community.

### LOCAL FABRICATION

Ilima has a condition of incredible remoteness, which made it essential that the design did not rely on any imported materials or labour. The school was built entirely by 160-170 people from Ilima and the surrounding villages of Bolima and Lotulo. Labour-intensive processes of hand production were prioritised in order to create opportunities for employment and craft and inspire a sense of pride and ownership of the structure.

### CAPACITY BUILDING

Construction of the Ilima School was a great opportunity for skills-development in the region. The community had virtually no experience reading construction documents, so MASS developed colour-coded graphic representation that allowed often illiterate workers to assemble the building’s complex roof frame. MASS also trained two Congolese architecture fellows in high-impact design construction methods, granting them the responsibility and leadership roles they needed to develop professionally.

### RESEARCH BY DESIGN

The architects optimised the construction process by applying vernacular materials in creative ways. Material research and innovation was undertaken to develop and enhance traditional techniques, rather than to prescribe new foreign ones, resulting in a resilient and highly adaptive facility with a low ecological footprint.

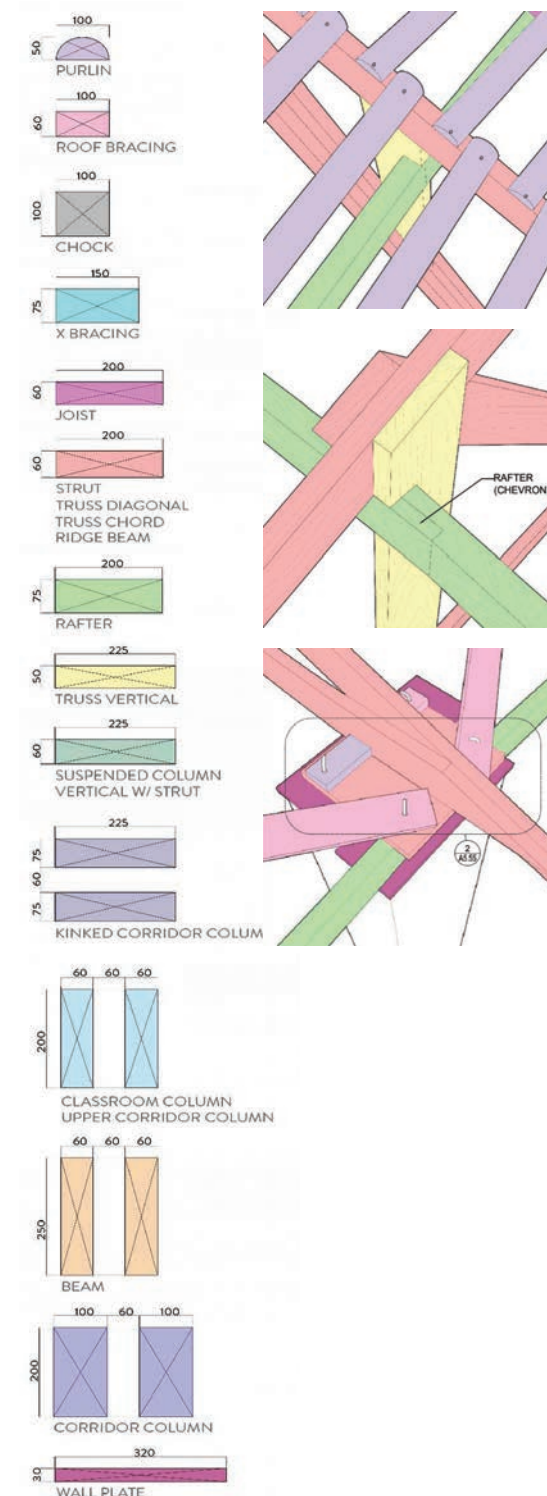



## SUSTAINABLE MATERIALS

The issue with using outside source material is that eventually, sometime down the line, that material will erode and if more cannot be sourced, then the building will ultimately turn into a ruin. Due to difficulty of accessing Ilima by road, the school was purposefully designed and built with 99% of materials sourced from within 10km of the site, so that it could be easily maintained well into the future.

### MUD BRICK

Walls are made of sun-dried adobe brick, comprised of earth from termite mounds, which creates a stronger cohesion. They are plastered with two layers of a clay-sand mix, white clay rendering, and two coats of boiled palm oil, the last ingredient – an innovation that makes the bricks more resistant to water. They sit on a laterite and compacted-soil foundation.

### HARDWOOD ROOF STRUCTURE

MASS collaborated with local conservationists to identify appropriate trees within 6km of site, which were hand-sawn, planed, and crafted into Lifake tropical hardwood trusses, roof framing, furniture and architectural details of the final facility. Lifake performs well in outdoor environments so treatment was not required.

### HARDWOOD SHINGLES

Local builders and MASS developed a method for transforming local trees by hand into durable and replaceable wood shingles. While wood shingles are not common in the Congo, the architects knew they would be easier to replace and maintain than a metal roof that had to be brought in from somewhere else. The innovation has been repeated on numerous local houses, creating a micro-economy for the community.

### WEAVING

The doors are made from Lifake hardwood frames with a peeled Lilian vine weaving, which was dried before use to avoid shrinkage.



## ENERGY GENERATION

### CARBON NEUTRALITY

As with many rural schools in East Africa, Ilima Primary School has no operational energy requirements, as there is no electric lighting or mechanical appliances. This means that 100% of the building's lifecycle emissions consist of embodied carbon. In Ilima's case, 93% of materials by weight were manually extracted earthen materials, which make zero contribution to CO2 emissions.





## SOLAR SHADING

### ORIENTATION

Although the sun is directly overhead on the equator, the sun path is still subject to variation over the course of the year, appearing to the south from October-March and to the north from April-September. Ilima Primary School is orientated on the east-west axis to maximise solar shading, but the building form also responds directly to the local sun path. This means that classrooms remain completely shaded throughout the whole year, even when the sun is at its lowest.

### OVERHANGS

The Ilima design takes a cue from regional and climate-aware design practices with a steep roof and gutter system to respond to heavy rainfall, coupled with extra-large overhangs to provide protection from sun for the classrooms and common areas.

Ilima Africa Sun Path

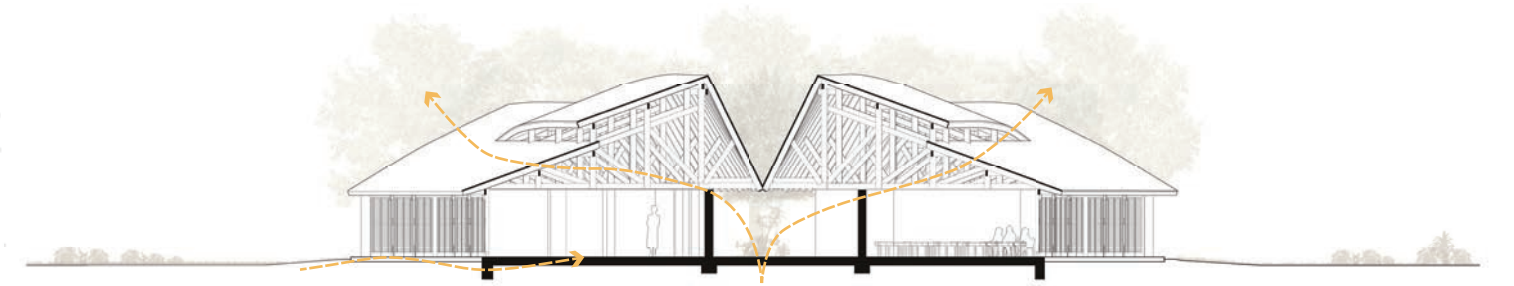
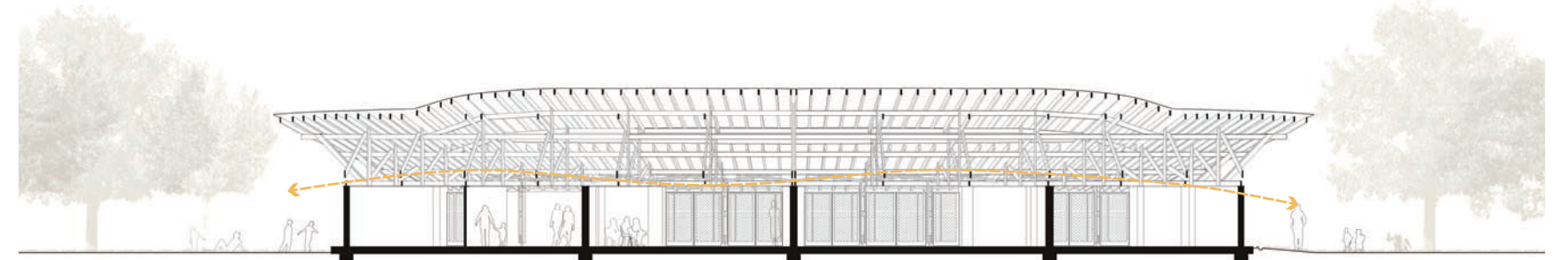
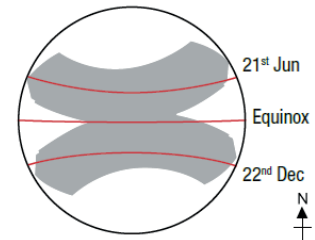

## PASSIVE VENTILATION

### CROSS/STACK VENTILATION

With no mechanical ventilation and zero electricity, the building is designed with an open clerestory to accommodate the hot climate. Internal walls only reach two-thirds of the ceiling height to allow unrestricted airflow, encouraging natural ventilation and daylight to create comfortable classrooms. High level horizontal vents in the roof allow hot rising air to escape through stack ventilation.

### OPENINGS

Perforated pivoting woven windows and doors allow air and light to pass through them even when closed during bad weather conditions.



# 4 NATIONAL TEACHERS' COLLEGE KALIRO

Location	Kaliro, Uganda
Architect	FBW Group
Client	MoES Uganda / Enabel
Consultant	Transsolar (Environmental Engineer)
Size	615m <sup>2</sup> (typical classroom block)
Cost	\$482/sqm inc. VAT (typical classroom block)
Year	2014

National Teachers' College, Kaliro is a secondary school teacher training college located in rural Uganda. In 2013 the existing infrastructure was dilapidated and inadequate and as a result the college could not provide effective and quality training. The Ministry of Education and Enabel appointed FBW Architects to develop the masterplan and detailed design for an improved campus. The aim is to provide a sustainable design solution, which addresses space, function, energy needs and that above all creates a comfortable and conducive learning environment.

The design approach seeks to optimise natural resources, integrating with and capitalising on existing amenities. The architecture aims to strike a balance between analysis, context and beauty. The emphasis is on providing effective, simple solutions to meet both explicit and implicit objectives, while utilising appropriate technologies that reflect significant innovation and provide tangible return. The dramatic overhanging roofs and expressive space frame provide a unifying architectural language, while also providing ventilation, protection from direct sunlight and rain, and the ability to efficiently harvest rain water.



## GENERAL ARRANGEMENT

The new NTC Kairo campus includes a library, classrooms, workshops, laboratories, administration offices, student accommodation and staff housing. Two existing administration and teaching buildings - Blocks X and Y - have been updated, while a further four new-buildings - Blocks C1, C2, D and E - have been added to the masterplan.

While the original buildings are made up of clusters of small spaces the new blocks designed by FBW are long rectangular buildings each with a single mono-pitch roof. They contain the library, a laboratory and several lecture rooms, punctuated by external teaching spaces.



THE NEW LIBRARY - BLOCK C1



EXTERNAL GATHERING SPACE - BLOCK D



ENTRANCE AND CARPARK

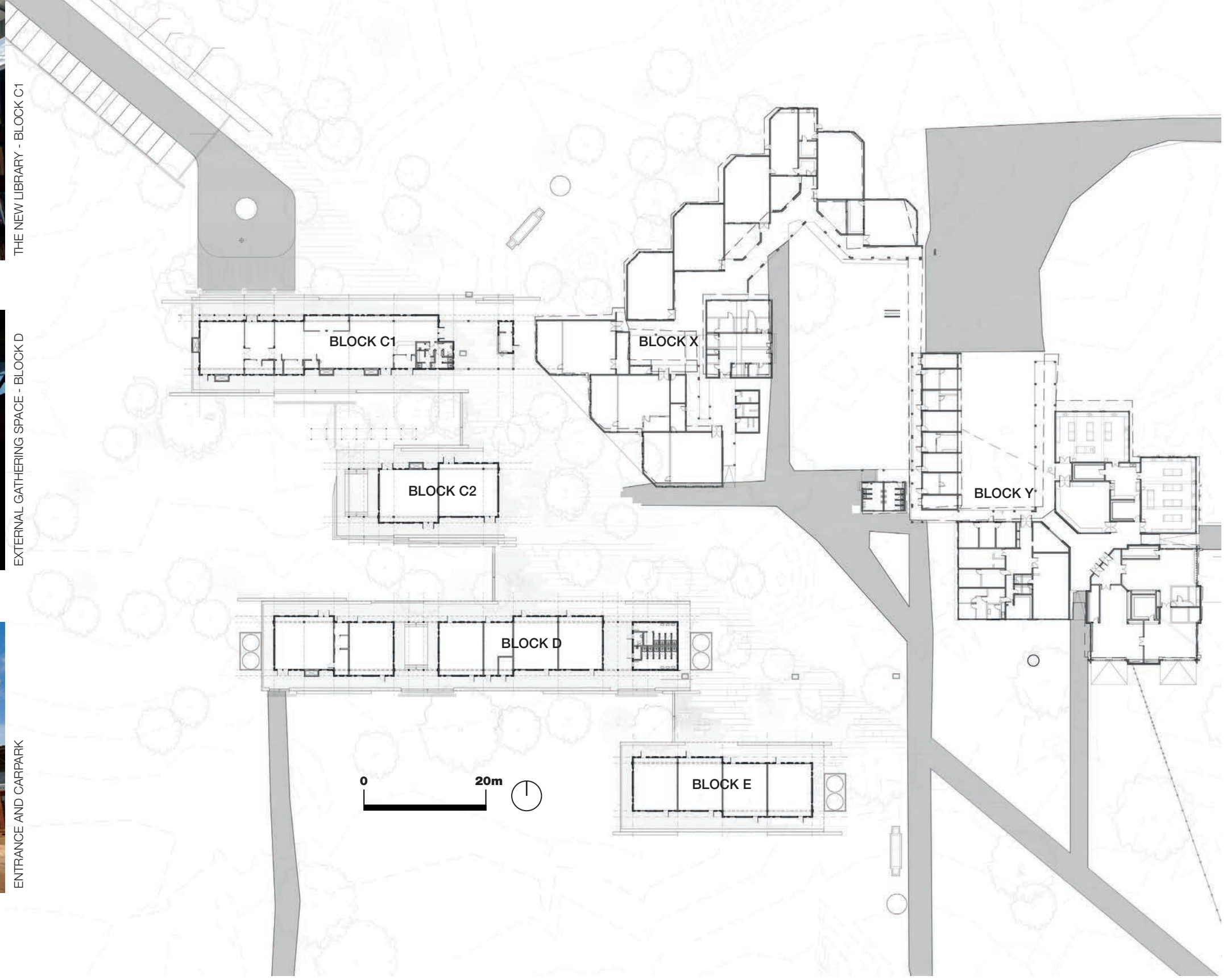

## SOLAR SHADING

### ORIENTATION

All new-build blocks have been orientated on the east-west axis for optimized solar protection. This is the defining feature of FBW's 3-phase masterplan, which proposes that the original campus buildings should eventually be replaced with new structures orientated according to tropical design principles.

### OVERHANGS

Each new-build block has a large overhanging roof to shade the external walls of the building and reduce solar gain from heating the fired brick walls.

### DOUBLE ROOF

Each of the rooms is enclosed by a suspended plaster ceiling, with a ventilated roof cavity. This air space helps to prevent thermal transfer from the metal roof sheets to the rooms below. The cavity is protected from driving rain by mild steel louvres, which in practice limit the air flow through the space. Selecting wider louvres or removing them all together could improve the passive cooling effect.

FBW CONCEPT MASTERPLAN - PHASES II&III 2020-2034



FBW CONCEPT MASTERPLAN 2015-2019

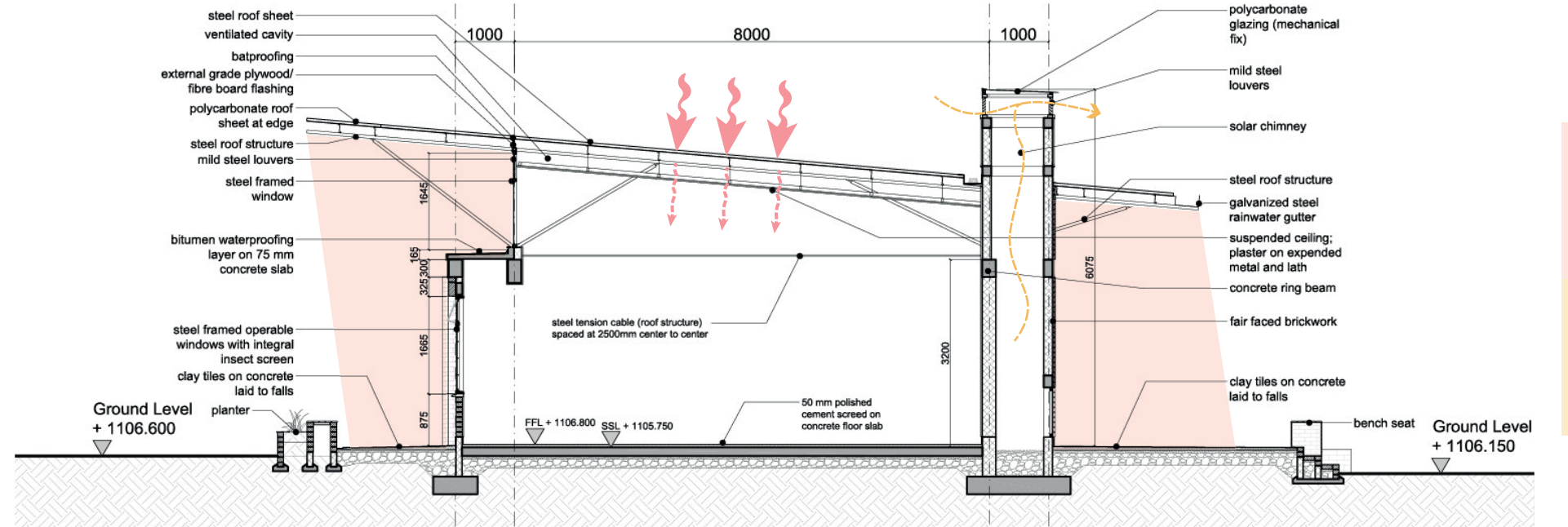
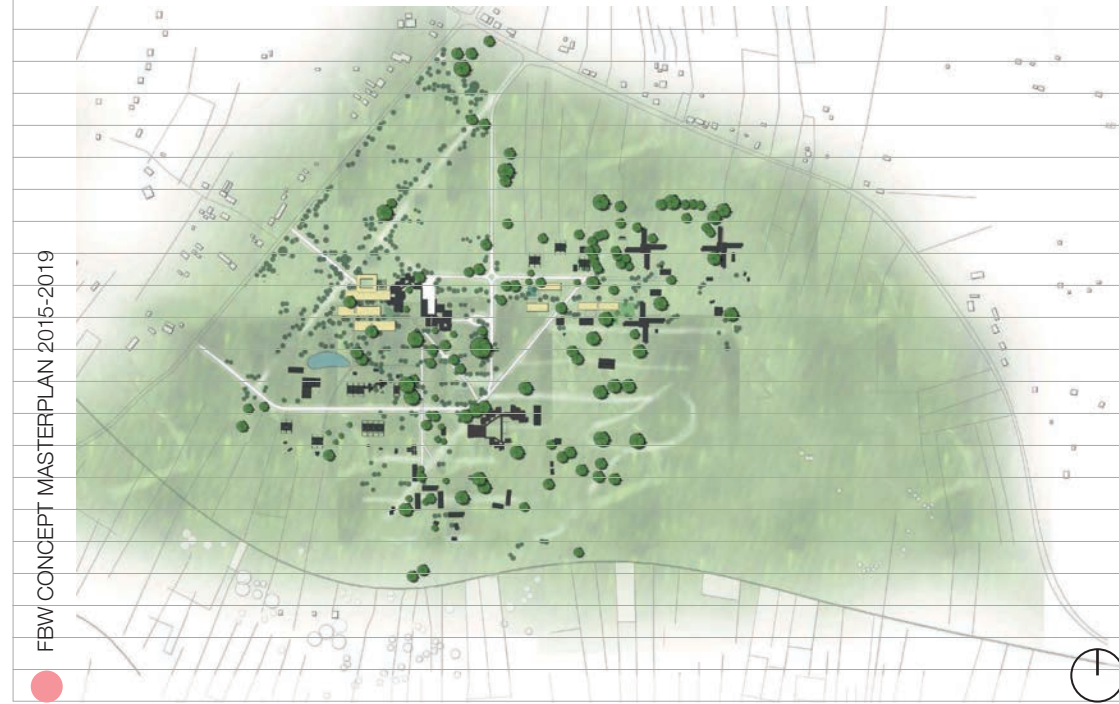

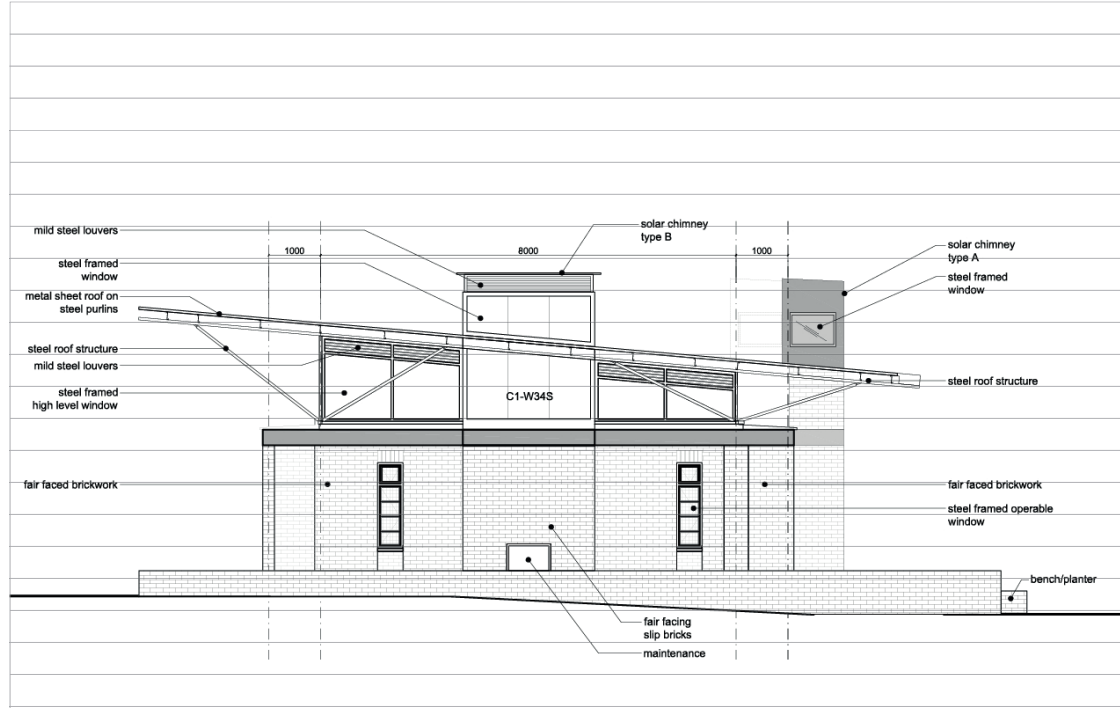

DOUBLE DOOR CONCEPT TO FACILITATE NIGHT-FLUSHING

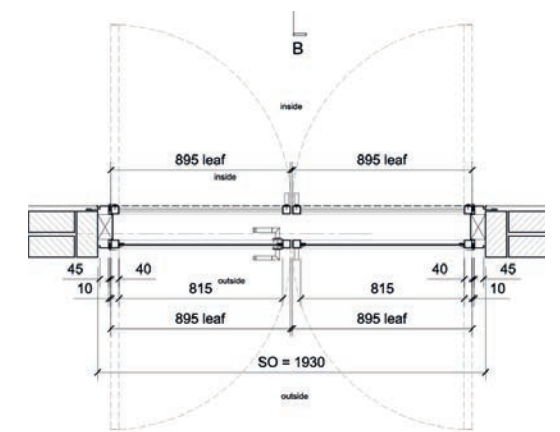

Library Ventilation Area		4
Total of ventilation louvres	Area restrained through louvres (aFOA ~ 0.69m <sup>2</sup> ), aFOA ~ 0.69m <sup>2</sup> /Area 177m <sup>2</sup> =0.39%	3
Total of operable openings (inc doors)	Total operable openings=48.06m <sup>2</sup> , aFOA doors=4m <sup>2</sup> (2 double doors) aFOA 90owindows=19.75m <sup>2</sup> , aFOA awning windows=2.2m <sup>2</sup>	5
Cross ventilation potential	Good cross ventilation potential, windows on both sides but tall shelves in the middle	2
Potential to open at night	Through louvres (the ventilation doors are not used) and burglar proof windows with mosquito net but probably windows must stay closed to protect books	3
Chimney	2 vertical chimneys, solar component insignificant, potentially wind catching	2
Language Lab Ventilation Area		4
Total of ventilation louvres	Area restrained through louvres (aFOA ~ 0.11m <sup>2</sup> ), aFOA ~ 0.11m <sup>2</sup> /Area 85.13m <sup>2</sup> =0.13%	2
Total of operable openings (inc doors)	Total operable openings=15.72m <sup>2</sup> , aFOA doors=4m <sup>2</sup> (2 double doors) aFOA 90owindows=3.3m <sup>2</sup> , aFOA awning windows=0.4m <sup>2</sup>	4
Cross ventilation potential	Great cross ventilation potential, doors located diagonally favourable for the SW wind sector	5
Potential to open at night	Through louvres (the ventilation doors are not used/wrong design)	2
Chimney	1 vertical chimney, solar component insignificant, potentially wind catching	2
Lecture Room Ventilation Area		4
Total of ventilation louvres	Area restrained through louvres (aFOA ~ 0.21m <sup>2</sup> ), aFOA ~ 0.21m <sup>2</sup> /Area 63.67m <sup>2</sup> =0.32%	3
Total of operable openings (inc doors)	Total operable openings=14.4m <sup>2</sup> , aFOA doors=2.3m <sup>2</sup> (2 single doors) aFOA 90owindows=4.76m <sup>2</sup> , aFOA awning windows=0.5m <sup>2</sup>	4
Cross ventilation potential	Good cross ventilation potential, 2 single doors located diagonally	4
Potential to open at night	Through louvres (the ventilation doors are not used)	2
Chimney	-	-

## PASSIVE VENTILATION

### PREVAILING WIND

The climate in Kaliro is relatively moderate with prevailing winds on a north-south axis. Classrooms have been designed with northern and southern orientated openings in order to optimise cross ventilation.

### STACK VENTILATION

A major sustainable design feature was the inclusion of solar chimneys, which were intended to provide both stack ventilation and architectural expression. In practice, the solar component has been found to be inadequate, instead they function better as wind catchers. This could be because they are not high enough to create sufficient suction to draw air from the interior spaces. Locating solar chimneys on the taller side of the building would help to improve their function.

### NIGHT COOLING

The design features a double door concept, where the interior door is fitted with burglar bars and a mosquito net, while the outer door is fitted with glass. This enables the outer door to be left open at night-time so that warm air can escape from the building. Unfortunately ensuring this habitual behaviour can be challenging as in practice, people feel uncomfortable with leaving doors open.



## PARTICIPATORY PROCESS

### PERFORMANCE BASED-DESIGN

Transsolar has been involved in an advisory role since the planning stages of the masterplan and new-build blocks. They have undertaken site visits and measurements of the thermal performance of existing buildings to be renovated. They have performed quantitative analysis using computational thermal building simulations of various future building typologies and elements to inform propositions for a comfortable (thermally, visually and acoustically) and conducive environment to foster inspired learning.

### POST-OCCUPANCY ANALYSIS

Transsolar concluded their work with a final assessment of the implemented measures. This comfort assessment has been based on interviews, on-site measurements and long-term recorded data and has helped to evaluate the performance of the new buildings so that the architects can learn from their successes and failures.

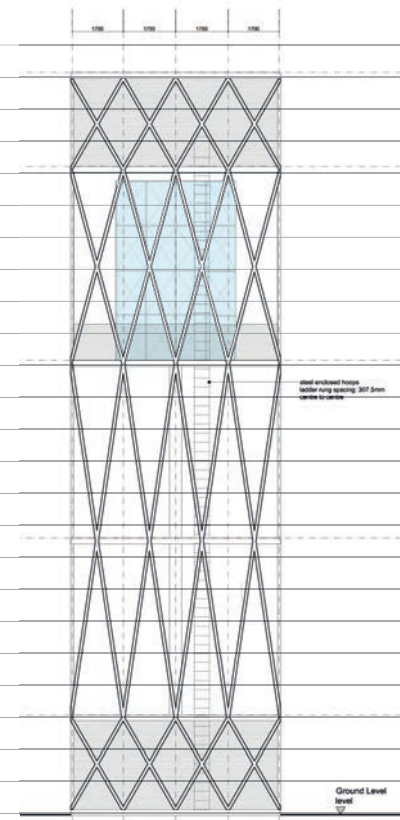

## WATER MANAGEMENT

### WATER SUPPLY

There is constant and reliable water supply from rainwater harvesting, boreholes, water reservoirs and an underground water pump.

### RAINWATER HARVESTING

The large mono-pitch roofs provide effective rainwater harvesting with a single gutter located along the lower edge. This channels water into two large plastic tanks at the ends of each of the buildings.

### PLASTIC TANK

The plastic tanks are partially concealed with steel framed bamboo screening to protect them from harmful UV and prolong their lifespan.

### STEEL TANK

A dilapidated existing water tank stand has been replaced with a new steel tower structure housing a 100,000L steel water tank.



## WASTE MANAGEMENT

### BIODIGESTER

Foul drainage is a normal waterborne system that flows to the lowest part of the site where a large PVC 'zeppelin' digests the waste. Sludge is collected and used for fertilizer, liquid waste drains into a reed bed and the gas created is used in the kitchen for cooking.

### DRAINAGE

Extensive storm drainage channels have been incorporated into the landscape that flow into the nearby water reservoir.

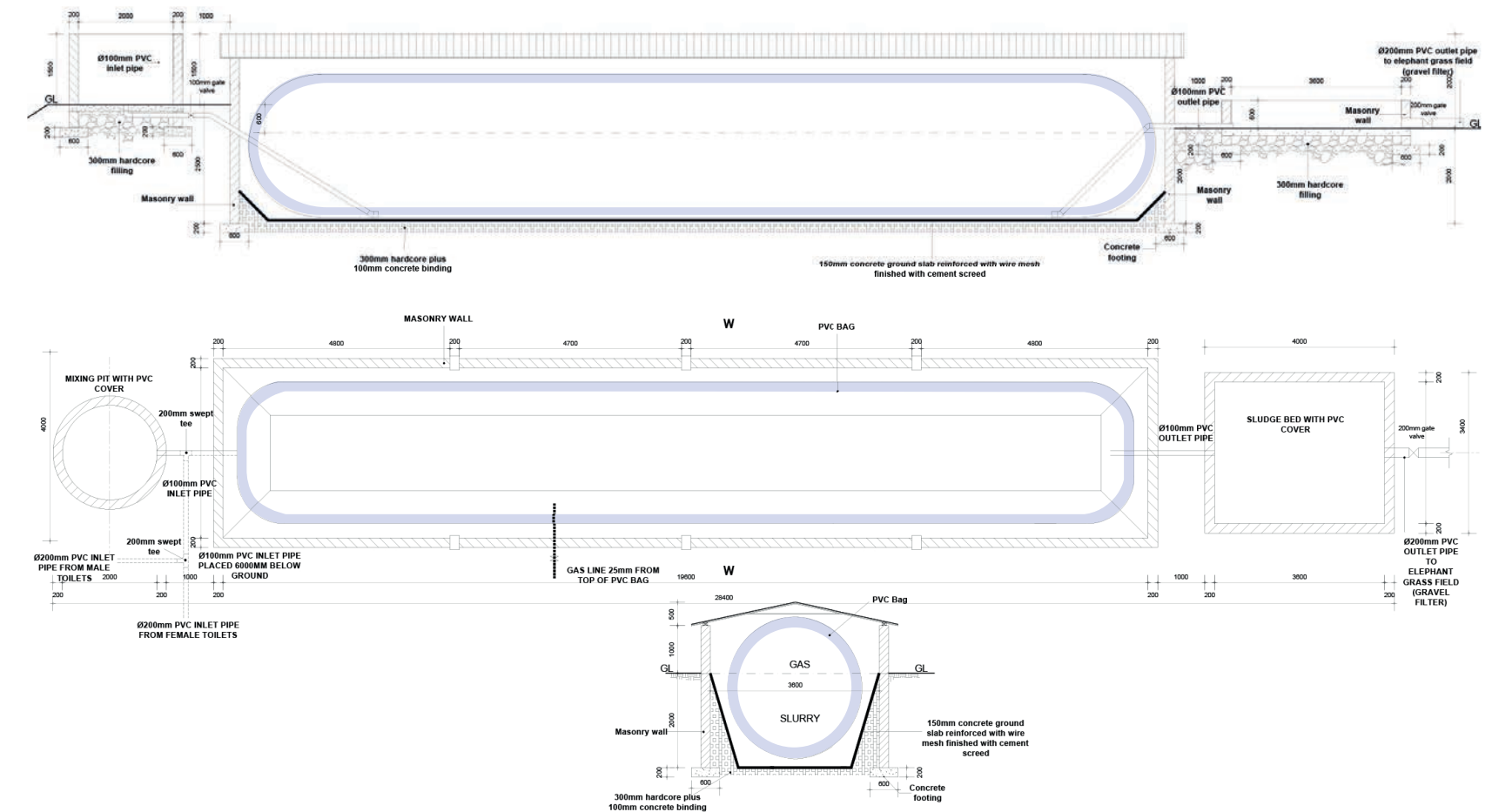



# 5 LAKE BUNYONYI VOCATIONAL SECONDARY SCHOOL

Location	Lake Bunyonyi, Uganda
Architect	Feilden Foundation / FCBstudios
Client	Lake Bunyonyi Christian Community Vocation Secondary School (LBCCVSS)
Consultant	Happold Trust (Buro Happold) / Feilden Fowles / Carpenter Oak
Floor Area	-
Cost	2008-2010 Phase1 \$30000 2010-2011 Phase2 \$35000 2013 Dormitory Phase 1 \$50000 2016 Dormitory Phase 2 \$13500
Year	2008-present

Lake Bunyonyi Secondary School is a vocational boarding school, where education is regarded as an holistic process. The school occupies a steeply sloping site on the edge of Lake Bunyonyi, near Kabale in southwest Uganda. The Feilden Foundation has been working with LBVSS for over a decade to develop it from a single classroom in 2007 to a school for more than 300 children today.

The principal challenge on the site is the lack of flat land on which to build classrooms and the need to create retaining walls and pathways up and down the site that are not subject to erosion. Every new building is equipped with rainwater collection tanks to help reduce runoff and provide a useful water supply for washing and cooking. The Feilden Foundation has also focussed on developing the sustainability of the school from a financial and pedagogical perspective by improving accounting and investment in agriculture.



### GENERAL ARRANGEMENT

Buildings constructed over a series of phases stretch out along the contours, connected by a network of decorative stairs and pathways. A significant circular structure is the focus of the campus, which houses the dining area and school communal activities. A kitchen, with enhanced ventilation, is built adjacent to it. The most recent building project, completed in 2017, is a two storey dormitory and classroom block.



DORMITORY AND CLASSROOM BLOCK

DOWNSTAIRS CLASSROOM IN BOY'S DORMITORY



SKETCH MASTERPLAN

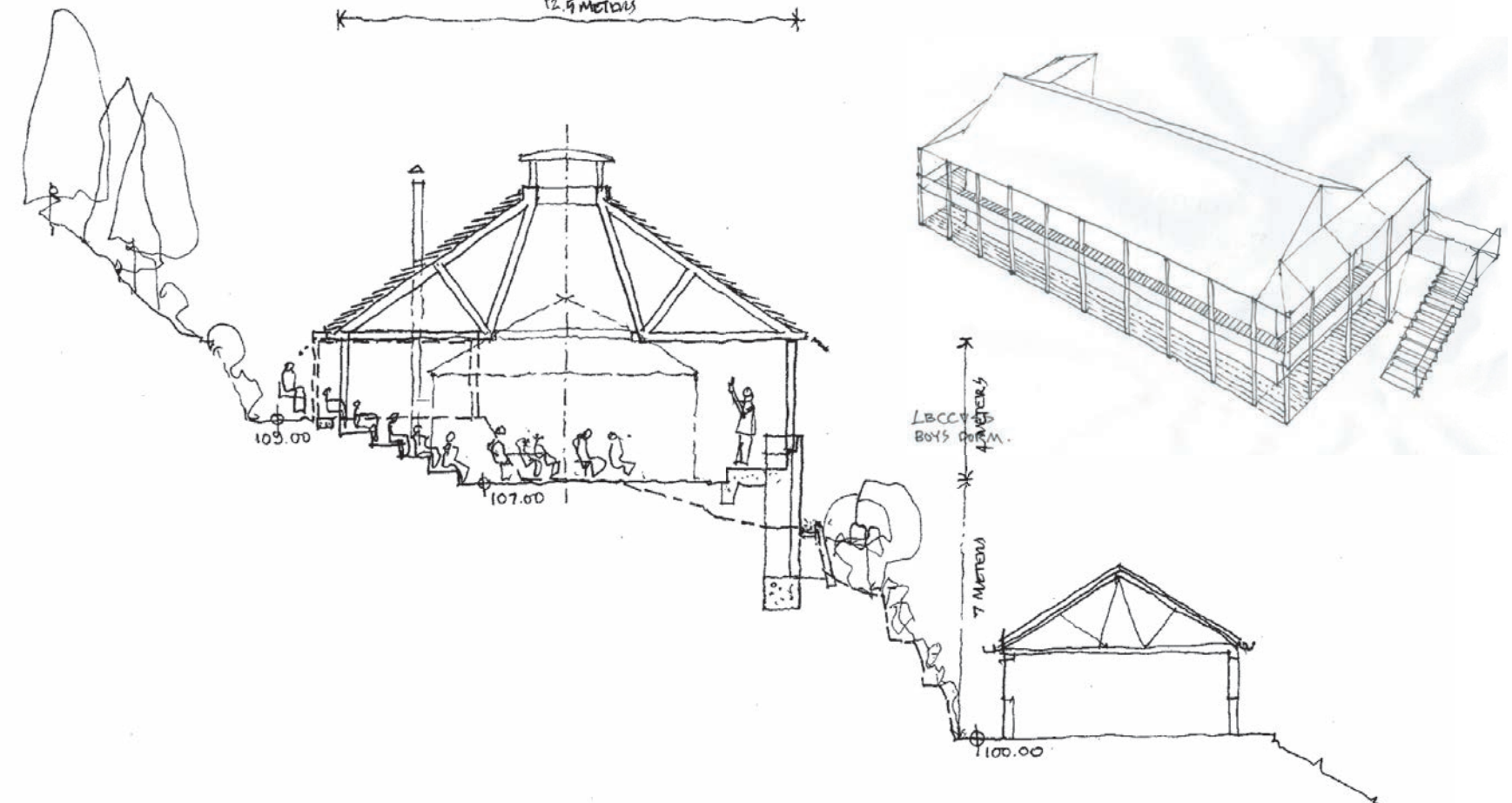
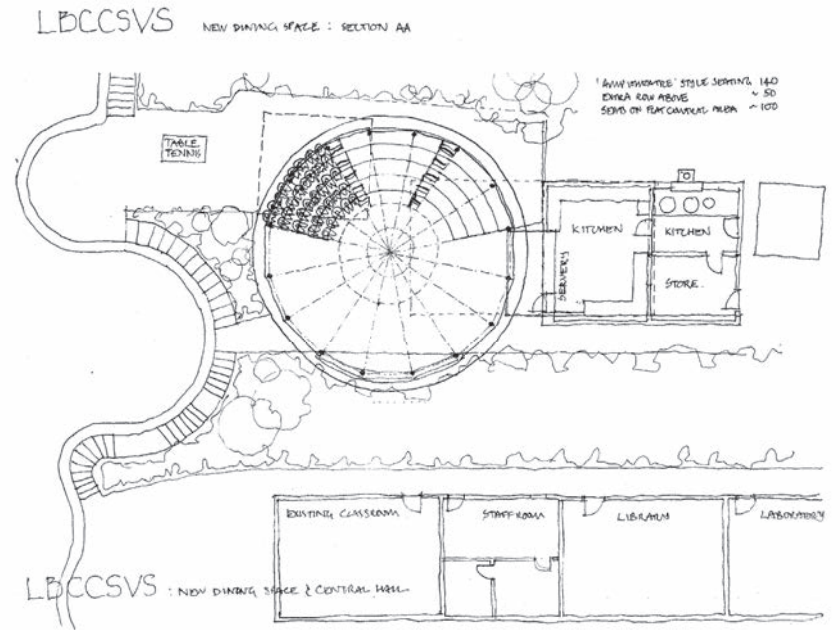
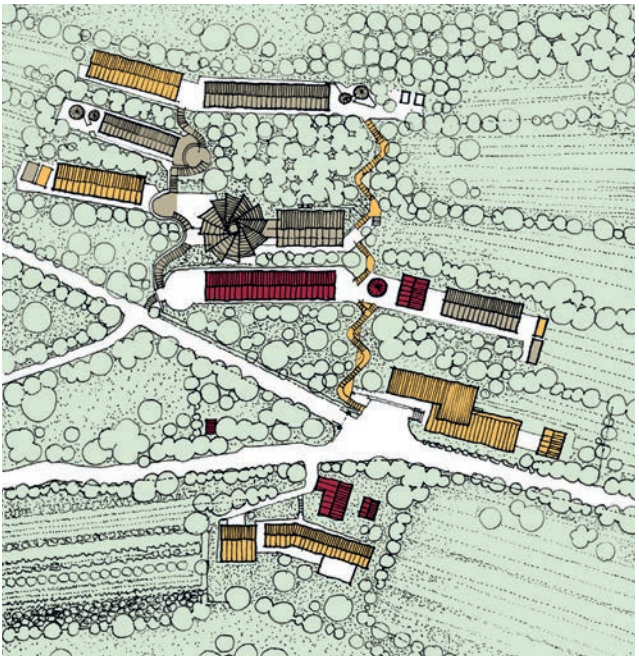

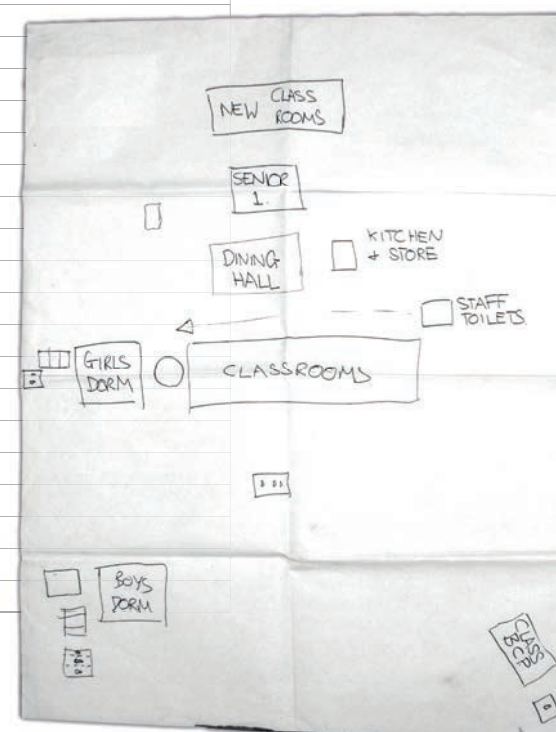
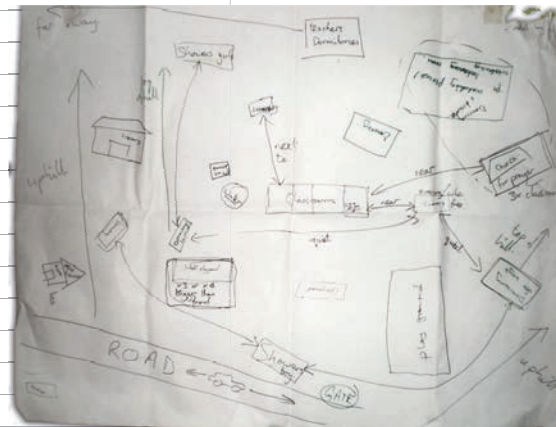
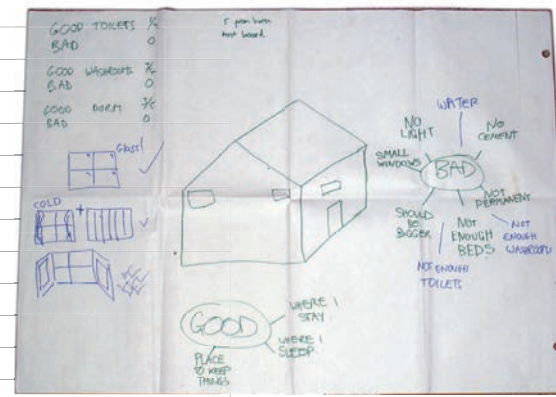

## PARTICIPATORY PROCESS

### IMMERSION IN CONTEXT

The Feilden Foundation approach was to look, listen, and learn, and to avoid pre-conceived ideas. Teachers were asked to show the architects around the school and explain what everything was, the problems and their future ideas. Pupils were asked to draw maps of the school, which were not accurate but helped to understand their interests and priorities.

### COLLECTIVE VISIONING

Workshops were held with teachers, pupils, local leaders and parents, to discuss the school's immediate needs and their aspirations for the future. The teachers drew up an action plan of short, medium and long term aims.

### PARTICIPATORY DESIGN

The school was involved in the design of every phase of the project. The Boys' Dormitory was intended by the designers to be a one-storey building, but increased to two-stories because of the aspirations of the school director.

### CAPACITY BUILDING

Pupils were taught how to survey and use a theodolite, which was later donated to the school. Vocational pupils were involved in the construction as part of their studies. Students worked closely alongside masons and skilled carpenters from Carpenter Oak, while Buro Happold employed and trained two site foremen to oversee the project.

### EMPOWERMENT

Pupils were given a timber step each to paint as an art project. This has created a beautiful and colourful staircase, and increased the pupils pride and enthusiasm for their school.



## SUSTAINABLE MATERIALS

### TIMBER FRAME

The Dining Hall superstructure is formed by 12 timber columns rising off galvanised steel baseplates with 12 large rafters supported at one end by a column and the other by resting “reciprocally” on its neighbouring rafter. This simple frame design creates a column-free internal space of over 10m in diameter. All timber was locally sourced from a small nearby eucalyptus forest.

### REINFORCED CONCRETE STRUCTURE

The two-storey Boys' Dormitory block is constructed from a heavily reinforced concrete frame to mitigate potential disaster arising from seismic activity. In order to reduce the amount of concrete required, bricks were inlayed into the first floor formwork to create an efficient cross section.

### FIRED BRICK WALLS

Bricks were moulded from good quality clay and dried in the sun before being stacked up into giant furnaces and fired for over 24 hours. This process utilises local material and injects money into the local economy. However, it also requires timber for fuel, which contributes towards deforestation, and can result in significant wastage as bricks are not fired consistently.



## NATURAL DAYLIGHT

### EVEN DISTRIBUTION

Large windows are uniformly spaced on both sides of the classroom to allow for an even distribution of daylight.

### DAYLIGHT CONTROL

There is no glazing to minimise cost and potential maintenance expense, with windows instead being fitted with wooden shutters that can be open or closed to control the quantity of light.



## WASTE MANAGEMENT

### PIT LATRINE

Previously the school built very temporary latrines, which once filled would be burnt down and covered over. These have been replaced with two permanent four-stance latrine blocks. Each pit is 35 cubic meters, hand dug with a concrete base and brick walls. They are internally plastered to reduce seepage, with a reinforced concrete slab cast at ground level. The new blocks are all located within 50m of the newly constructed access road so that they may be easily emptied whenever required.

A new urinal design has been implemented, which directs urine to a soakaway pit in order to alleviate unpleasant odour.

### DRAINAGE

The first project undertaken by the design team - principally led by engineers from Buro Happold - was to establish a stormwater drain running through the site that dealt with excessive runoff at times of high rainfall. The drain follows the line of steps which were built and decorated by the students. The open channel drain was created using fired bricks and incorporates rough textured bricks along the base of the channel to slow the flow of the water. The drain discharges into a long swale adjacent to the entrance road.



## SUSTAINABLE LANDSCAPE

### MITIGATION

A lot of effort has been put into slope stabilisation to mitigate landslides that might occur from excess rain or seismic activity. There have been several approaches to slope stabilisation: cut and fill landscaping to reduce the gradient, brick retaining walls, and sandbag retaining banks planted with elephant grass.

### PRODUCTIVITY

The school produces a lot of its own food, such as beans and cabbages, which significantly reduces its operational costs. An educational beekeeping enterprise has been implemented, where the amount produced outstrips the amount consumed. Excess is sold locally for 6000 UGX per kg, providing much needed additional income.

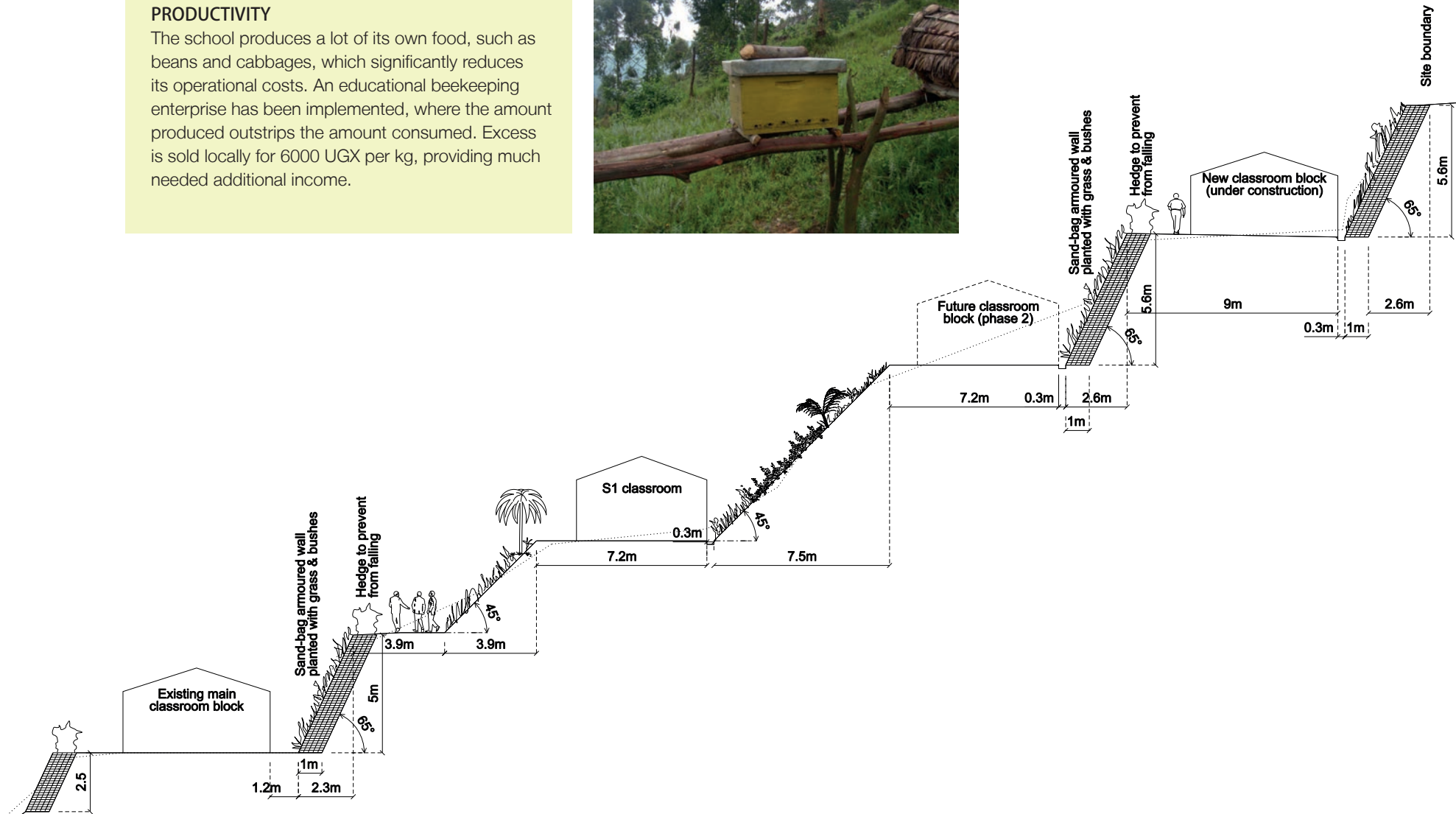

# 6 EARLY CHILDHOOD DEVELOPMENT & FAMILY CENTRES

Location	15 districts in Rwanda
Architect	ASA Studio
Client	UNICEF Rwanda
Consultant	Eng. Nyundo Kayihura
Size	500sqm
Cost	\$200/sqm
Year	2013-2016

The Early Childhood Development and Family Centres are one of UNICEF Rwanda's flagship projects, which have been implemented on a national level in 15 districts across Rwanda. The centres offer family and community empowerment by providing a stimulating start in life for babies, infants and small children. They are the result of an holistic approach to architectural intervention, designed by ASA Studio to strengthen the rural communities which they serve, forming a positive catalyst for change and poverty reduction.

The design draws upon important themes in community life, highlighting the role of a central space as a catalyst for community gathering, in a contemporary reinterpretation of the traditional "urugo" settlement pattern. The foremost requirement however, is for the design to be both replicable and adaptable to varying topographical constraints and geological conditions, such as soil type and rainfall. This led ASA to develop a modular system, where components can adapt to different terrains and situations, but come together to create similar facilities, organized around a central community gathering space. The buildings provide a safe and healthy environment with good light, ventilation and thermal insulation as well as access to water and sanitation facilities.



VENTILATION

LANDSCAPE

WATER

WASTE

## GENERAL ARRANGEMENT

The ECD&F design comprises a group of independent building modules connected via a roof and sidewalk. This allows for the deployment of a circular or S-shaped orientation to accommodate a variety of space and slope conditions, both of which create semi-enclosed courtyards.

There are five basic module types: the stimulation room, multipurpose hall, open demonstration kitchen, administration block and sanitation facilities. A continuous porch allows for a variety of covered outdoor spaces for both learning and communal activities. The whole compound is fenced and includes a dedicated area for playgrounds and kitchen gardens.



STIMULATION ROOM



SEMI-ENCLOSED COURTYARD



MULTI-PURPOSE HALL

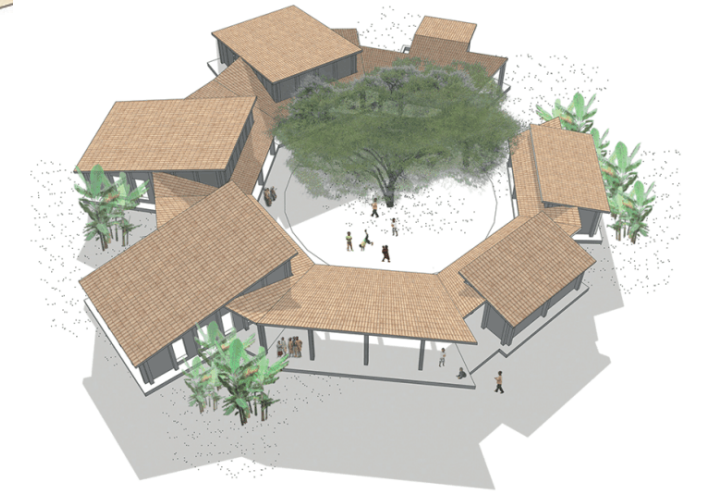
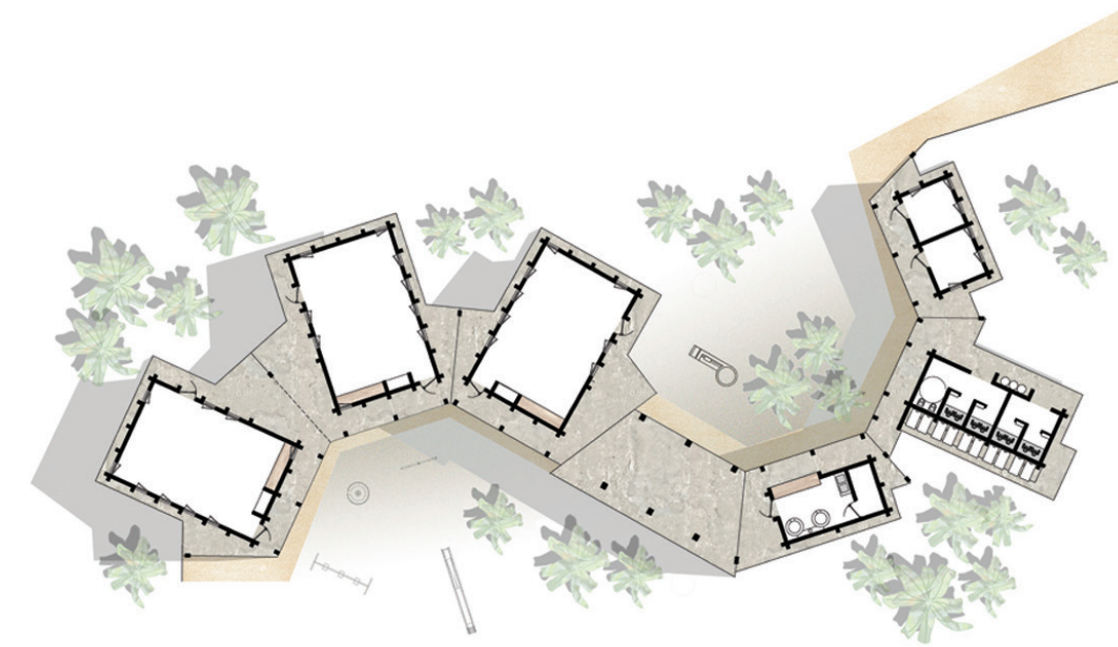
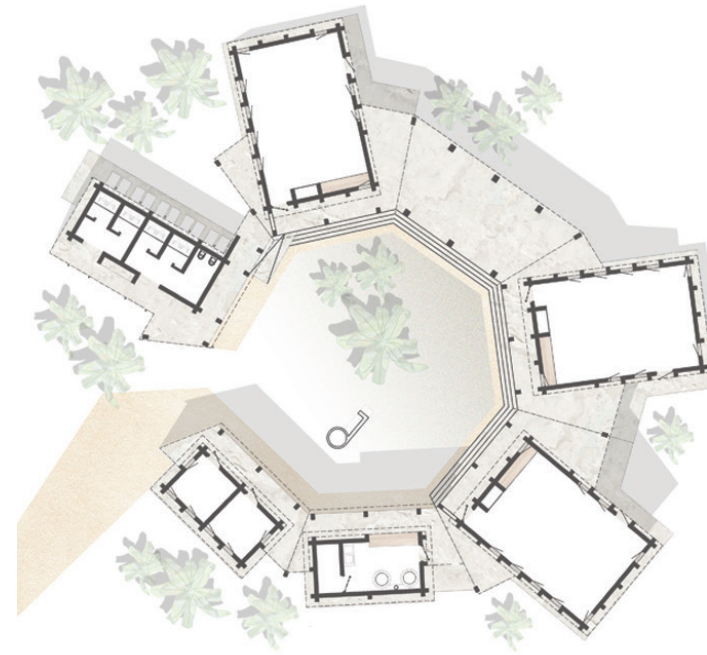

VENTILATION

LANDSCAPE

WATER

WASTE



## SUSTAINABLE LANDSCAPE

### PRODUCTIVITY

The construction and cultivation of a community garden at the centres was proposed as a means to expand the ECD&F programming with the integration of an environmental and nutritional curriculum for the local community.

Nurseries and kitchen gardens are designed to provide at least one healthy meal to the children of each community daily, while serving as a laboratory and educational tool, not just for the children but for the community as a whole. Each centre has also been constructed with a demonstration kitchen that can be used as a teaching facility to promote innovative agricultural and nutritional techniques.

### ACTIVE LEARNING

Early childhood development is best promoted through opportunities for stimulation and play. Recognizing the importance of play-based learning for young children, the ECD&F centres provide lots of opportunities for children to play and learn. All sites are provided with a selection of custom-made playground equipment including:

- Lime green, cow-shaped slide
- Bright yellow seesaw
- Light blue merry-go-round
- Swing set with three wooden seats
- Large sand pit adjacent to the sidewalk

To make the playground equipment accessible all year round, even in the rainy season, a thick layer of gravel covers the play area. All of the stimulation rooms are equipped with multiple blackboards for writing, including some located very low for children to access. The entire site has lots of outdoor covered space including exterior blackboards and a multipurpose hall for outdoor learning.





## WASTE MANAGEMENT

### WATER, SANITATION & HYGIENE

The WASH block is located according to the direction of prevailing winds. Each block is equipped with two stalls for girls, two stalls for boys, and one handicapped stall, all with plastic potty seats for use by the very young. There are child friendly hand wash stations labelled as “non-potable” at the latrine and in the kitchen, which also has a sink for cooking and cleaning dishes.

### ECOSAN TOILET

The centres use ecological sanitation (ecosan) technology, which diverts urine from faeces in order to ultimately use both for agriculture. Liquid waste is piped to a tank for use in irrigation and solid waste is mixed with water and exposed to the sun before it can be used as nutrients for crops.

The composting toilet is an efficient system that reduces the risks of underground water contamination and improves hygiene and comfort in the building by reducing smell and sealing from flies.



## PASSIVE VENTILATION

### OPENINGS

Multiple perforations within the brickwork contribute towards the aesthetic character of the centres, while providing passive ventilation and natural lighting. The ventilation holes and patterns have been strategically placed according to prevailing wind patterns so as to avoid wind and driving rain from entering into the interior.

### NIGHT COOLING

The permanent ventilation openings allow cool air to circulate through the building at night-time, helping to reduce the heat build-up gathered by masonry walls during the day.

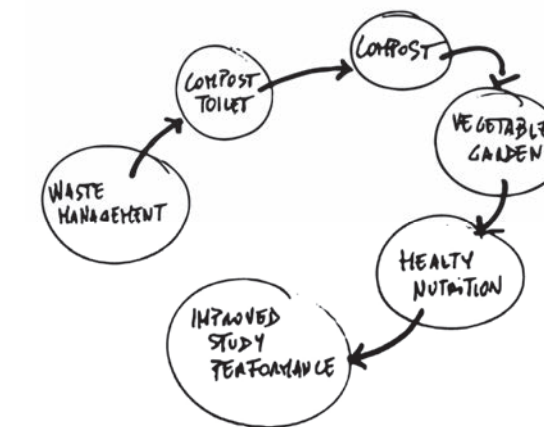

VENTILATION

LANDSCAPE

WATER

WASTE

## WATER MANAGEMENT

### WATER SUPPLY

The centres aim to be water self-sufficient, in order to reduce management costs and ensure easy and consistent access to fresh water, helping to improve sanitation procedures.

### UNDERGROUND TANK

A 35,000L underground rainwater tank has been included in the design so that the centres can provide a valuable resource for the greater community's daily use. The tank is a masonry brick dome with reinforced concrete foundation, and an inner and outer layer of waterproof plaster.

The tank is fed by gutters and downpipes that collect rainwater from an area of over 500m<sup>2</sup> of clay roof tiles. The water is pulled through a fountain activated by a pedal pump with no need for electric power. The children and their families are the primary users of the collected rainwater, but all who live close to the centre can access the fountain.



# 7 RUHEHE PRIMARY SCHOOL

Location	Musanze, Rwanda
Architect	MASS Design Group; African Design Centre
Client	M2 Foundation
Consultant	Nous Engineering (structural); Oak Consulting Group (civil); Ubatsi (structural); Transsolar (environmental)
Size	560sqm (building) 12000sqm (site)
Cost	-
Year	2018

Ruhehe Primary School is a public school that serves 1,120 students from pre-primary to grade six, with the help of 20 teachers and maintenance staff. Prior to its redesign the school lacked the appropriate infrastructure to support the demands of a growing institution. A much-needed renovation was undertaken by the inaugural cohort of African Design Centre (ADC) fellows, under the tutelage of MASS Design Group. The reconstruction at Ruhehe scaled lessons learned from Mubuga Primary School, MASS's pilot campus for a vision to redesign learning environments in Rwanda. The ADC's design-build curriculum provided a unique opportunity to develop this framework that could be iterated nationwide for improvements in education.

Through an extensive Immersion process, ADC fellows were able to produce a community-centered design concept that emphasizes capacity building at all stages. The project aims to prove that better infrastructure can improve learner outcomes, increase satisfaction among students and teachers, and increase student retention rates. The redesign strategically fits within a budget relative to that of school reconstruction in Rwanda, so that the process, materials, and staffing can be scaled across the country.



## GENERAL ARRANGEMENT

The ADC's and MASS's elegant solution for Ruhehe was to create two gently curving 5m high parallel boundary walls from which four new one-storey buildings branch toward the west. This plan separates the classrooms from a busy walking path, protecting students from distractions and creating a sense of an enclosed campus while preserving the school's connection to the community.

The new buildings contain five new classrooms, a library, headmaster's office and administration facilities. Two existing classrooms have been renovated for optimal use. The redesigned campus also includes designated playscapes and a community plaza. The innovative design utilizes locally sourced materials to create active learning spaces.

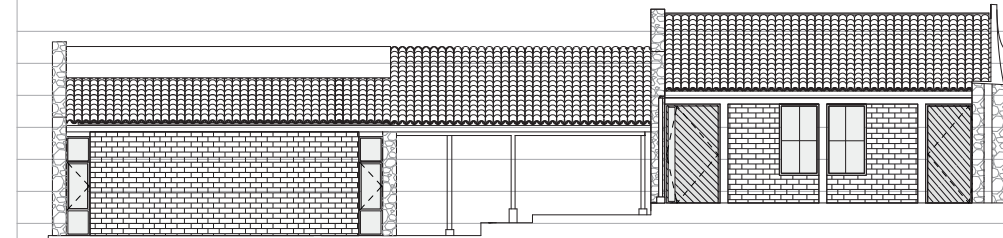

Block 3 - Northeast Elevation  
1:50

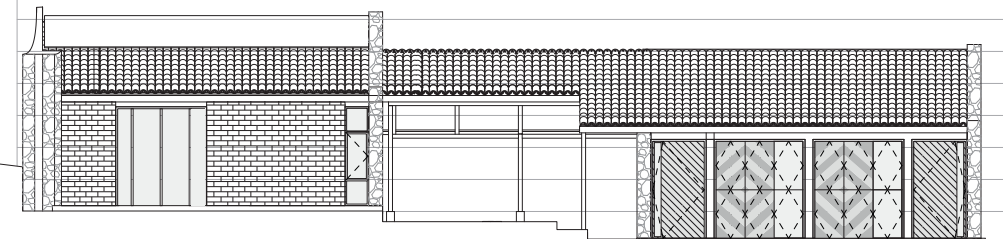

Block 3 - Southwest Elevation  
1:50



VOLCANIC MOUNTAIN SCENERY

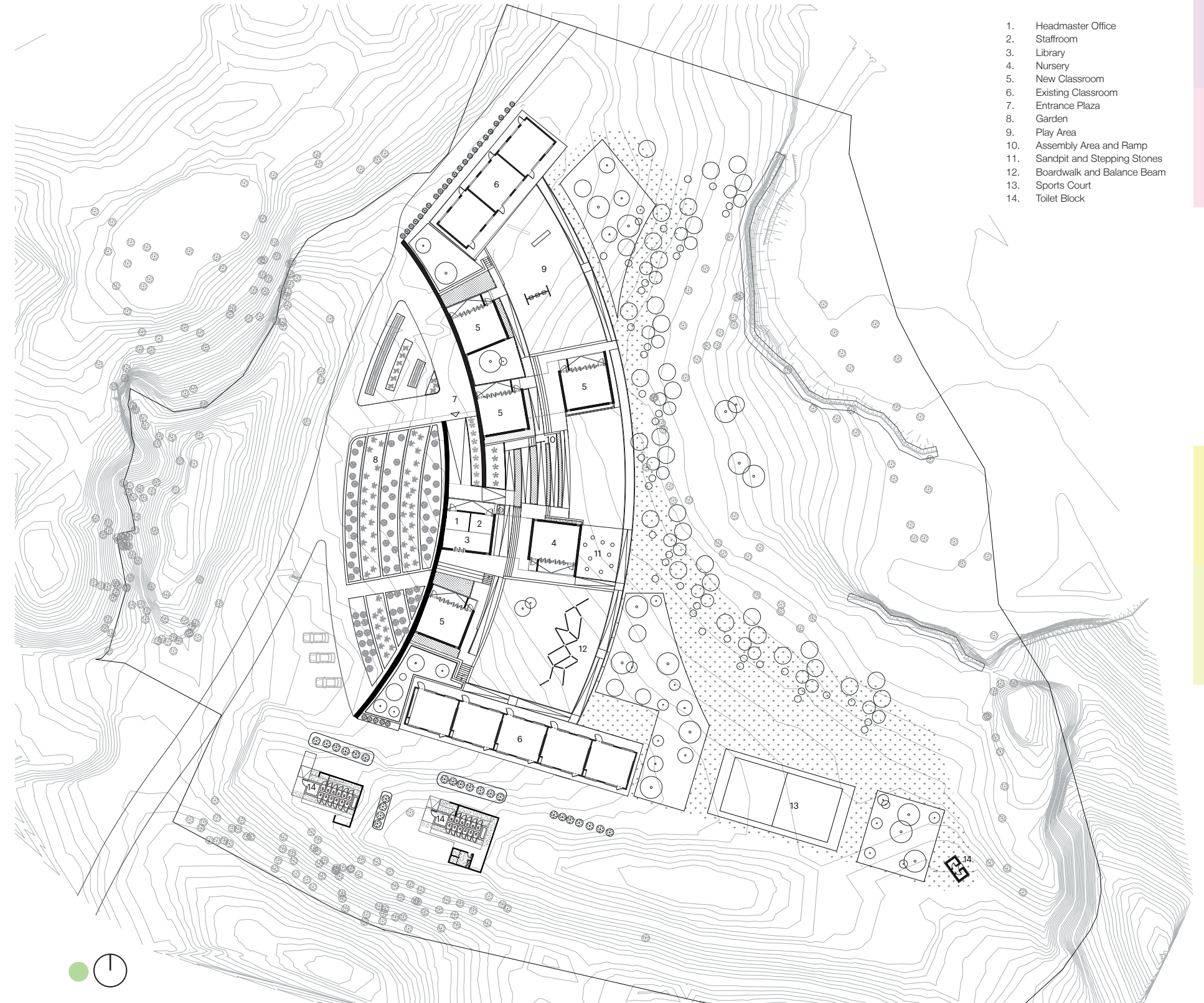

1. Headmaster Office
2. Staffroom
3. Library
4. Nursery
5. New Classroom
6. Existing Classroom
7. Entrance Plaza
8. Garden
9. Play Area
10. Assembly Area and Ramp
11. Sandpit and Stepping Stones
12. Boardwalk and Balance Beam
13. Sports Court
14. Toilet Block

## PARTICIPATORY PROCESS

### CAPACITY BUILDING

MASS launched the African Design Centre in 2016 to respond to the lack of skilled design and construction professionals within the booming African population. The programme aims to build a network of architects who can help to design more equitable and sustainable cities.

The course is a 20-month, multi-disciplinary programme, which culminates with a live design-build project. Ruhehe Primary School was the live component for the initial cohort of ADC fellows. Since the programme's completion, half of the fellows have continued on to full-time positions at MASS, while others have joined architecture practices in their home countries.

### IMMERSION IN CONTEXT

The programme focussed on teaching ADC fellows methods of immersive research that would place them in direct proximity to the community. Applying this training, the fellows led activities and workshops to determine how a redesigned campus could best address the needs of the Ruhehe community.

### LOCAL FABRICATION

During a period of pre-design immersion, the ADC fellows discovered that there was a high rate of local unemployment, particularly amongst youth. In response to this, they focussed their design on hand-crafted materials and labour-intensive construction methods, which provided work for 110 labourers from the local community, 35% of which were women, 18% of which were youth.





## SUSTAINABLE MATERIALS

During initial site visits, the ADC surveyed the old buildings, assessing their capacity to safely fulfil their functions, so that as far as possible their structures and materials could be reused or recycled. Expanding upon this data, the fellows sourced materials within close proximity to the site to minimize embodied carbon. Over 80 percent of materials used in construction were sourced from within 50 kilometers of the site, with 75% of the budget spent in Ruhehe Village and Musanze district.

### CONCRETE WALLS

The two sweeping boundary walls are constructed from reinforced concrete clad with local volcanic rock. Ruhehe is in a seismic zone, so concrete and steel are necessary, but expensive and not easily attainable. The architects made attempts to limit their use where possible and source 100% recycled steel reinforcement.

### VOLCANIC ROCK CLADDING

The volcanic rock cladding pays homage to the existing vernaculars of Rwandan stone working, but is built around a central core of steel and concrete to guarantee its strength and stability. The walls dip and peak following the profile of the nearby volcanic mountains turning the entire campus into a space of play and active learning. The peaks line up with the slope of the building roofs and the stone clad walls are exposed to the interior spaces.

### CLAY ROOF TILES

The fired clay tiles are a sustainable and locally sourced roof covering system made from clay sourced from approved quarries by local regulators. The tiles have better thermal properties than metal sheets and help to reduce the sound of rain, allowing learning to continue during storms.

### TIMBER CEILING

The ceiling material is tongue and groove Cypress boards painted with a coat of boiled Linseed oil.

### CONCRETE FLOOR TILES

Concrete floor tiles contain volcanic stone dust as a substitute for fine sand. The dust, which is a by-product of cutting the volcanic rock, replaced 25% of the sand needed for the ground pavers.

### WINDOW SCREENING

Vertical woven windows made from tree bark and bamboo ropes feature operable lower units that allow fresh air to enter the classrooms.

### RECYCLED MATERIALS

Scaffold poles used during construction were up-cycled into fencing, play equipment, toilet screens and water tank screens.





## NATURAL DAYLIGHT

### ROOFLIGHTING

The new classrooms feature polycarbonate skylights that ensure adequate daylighting for comfortable reading and writing.

### REFLECTIVITY

Vibrantly decorated light shelves hung below the ceilings diffuse daylight that penetrates through the polycarbonate eliminating direct sun and glare.



## SUSTAINABLE LANDSCAPE

### ACTIVE LEARNING

A central plaza at the heart of the campus provides an outdoor assembly space for the school's community. The new outer yards feature built play spaces where students can congregate, socialise, and engage in recreational activity. The pavers feature patterns of local children's games, while play equipment is designed to stimulate better learning for different age groups. The sandpit and stepping stones, for example, are intended for the nursery programme, while the boardwalk and balance beam is for the senior section. Plant species have been selected according to the play programme.



# RWAMAGANA LEADERS' SCHOOL DORMITORY

Location	Rwamagana District, Rwanda
Architect	ASA Studio
Client	Rwamagana Leaders' School
Consultant	-
Size	835sqm (building) / 1500sqm (plot)
Cost	\$185/sqm inc. VAT (building) \$140/sqm inc. VAT (total)
Year	2015-2016

Rwamagana Leaders' School is a secondary boarding school in eastern Rwanda with a curriculum that focuses on sustainability. The new dormitory building, designed by ASA Studio, is intended to demonstrate the potential of empowerment in education through architecture. The building acts as a teaching tool that enhances the boarding school experience while stimulating the students and offering a safe and healthy environment. The result is an innovative and socially responsible solution that balances sustainability, cost effectiveness and functionality.

The adoption of a participatory design approach played a significant role in the positive outcome of the project, integrating the students' inputs, for a better understanding of the space. Thanks to step-by-step construction training, mock-ups, and on-site material testing, the workers learned how to improve their traditional construction techniques and adopt alternative locally available and affordable materials, such as clay, stone, lime and reeds. Simple passive design principles have been employed to ensure adequate daylighting and natural ventilation, which are fundamental to the interior comfort of students, enhancing their quality of life and study performance.





## GENERAL ARRANGEMENT

The spatial arrangement of the dormitory is driven by the need for a flexible layout that can accommodate a number of different activities in a typical student's schedule. The negative space between bedrooms creates common areas where the students can spend their free time, study and socialise. These spaces are designed to be as flexible as possible to create an adaptive and qualitative environment.

In the bedrooms themselves, a system of inbuilt furniture provides storage spaces and ensures privacy for each student. Although the rooms are modular in size, they are unique in their furniture arrangement, colours and aspect, helping children to foster a sense of identity and belonging that will improve and strengthen interpersonal relationships.



FRED-BRICK CLIMBING WALL

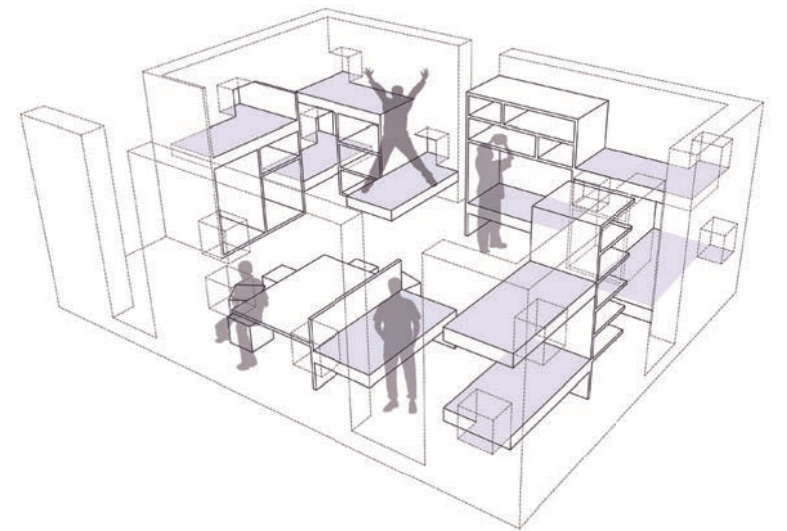
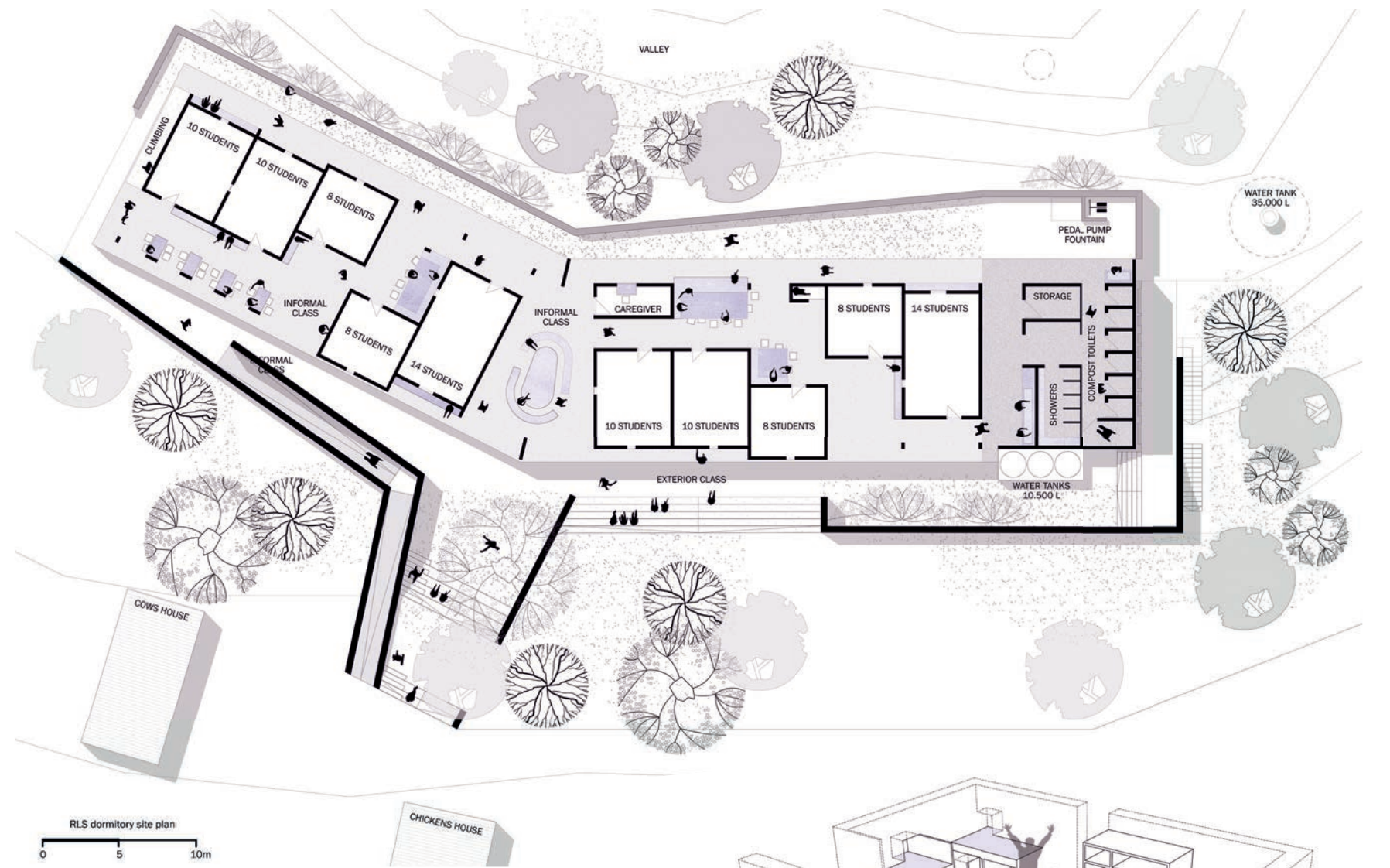

### 1. DORMITORY

A. Principal functions – What would you like to do in the bedroom of your dormitory? Please write your answer.

reading	1,2,3,4,5,7,9
sleeping	1,2,3,4,5,7,9
sports (physical recreation)	1,3,7
playing games (cards)	2,3,6
riding washing machine	3,7
hanging out	4,5,9
everything you mentioned	6
taking baths	7
study	7,8
would like to have chairs	8

B. Time - What time of the day are you in the bedroom of your dormitory and for how long?

weekdays: 4 pm - 5 pm, 7 pm - 6 am, 7 am - 8 am  
weekends: all day (1 pm - 5 pm sports)

C. Interior - How many boys would you like to share your room with? What kind of bed would you prefer? Please tick the box of your choice.

1,9    2,3,4,5,6,7,8    1,2,3,4,5,6,7,8,9

D. Aesthetics - What do you like your dorm to look like? Colors, materials, texture? Please tick the boxes of your choice.

7,9    4,5,6,8    8    2,3,6,7    9    1

### 2. COMMON SPACE

A. Principal functions – What would you like to do in the common space of your dormitory? Please write your answer.

reading	1,3,6,7,9
sleeping	1,9
sports (physical recreation)	1,2,3,4,5,6,8
playing games (cards)	3,9
washing machine	7,9
hanging out	1,2,3,6,8
study	7,9
informal classes	1,9
hammock	1,4,5,8
chairs	6,9
swing	6,9

B. Time - How much time would you spend in the common space to perform the activities you wrote?

at least 2 hours a day  
weekends and after class

C. Interior - What would like your common space to be like? What kind of furnitures and what kind of spaces would you enjoy? Please tick the boxes of your choice.

7,8,9    4,8    1,5    1,2,3,6,7,9

D. Aesthetics - What do you like your dorm to look like? Colors, materials, texture? Please tick the boxes of your choice.

7    1,2,3,4,5,6,8    8,9,7    3,9

### 3. TOILETS AND SHOWER

A. Principal functions - How would you like to use your bathroom of your dormitory? Any other thoughts about your bathroom? Please write your answer.

head showers	1,2,3,4,6,7,8
washing bike	3
cold and hot water	5

B. Time - What time of the day are you in the bathroom and for how long?

weekdays: 5:30 am - 6:45 am, 4 pm - 4:45 pm 10 pm,  
before and after school  
weekends: all day (1 pm - 5 pm sports)

C. Interior - What would you like your toilet and bathroom to be like. How would you like to shower to be, wall mounted over head shower or with bucket? Please tick the boxes of your choice.

1,3,4,5,6,7,8,9    5    1,2,3,4,6,7,8

D. Aesthetics - What do you like your bathroom to look and feel like? Colors, materials, texture? Please tick the boxes of your choice.

1,7,9    4,5,6    2,8    3,8    5,9    4,6

### 4. EXTERIOR SPACES

A. Principal functions - What would you like to do outdoor? Please write your answer.

reading	1,3,5
basketball	1,2,3,4,5,6,7,8,9 (not only football)
sports (volleyball)	1,2,4,5,6,7,8,9
pingpong	9
washing machine	7
seesaw	7
hammock	1,5,7
volleyball	9

B. Time - How much time would you spend in the common space to perform the activities you wrote?

2 hours every day  
6 am - 8 am  
9 pm - 12 pm  
2:30 pm - 5 pm

C. Exterior - What would like your common outdoor space to be like? What kind of furnitures and what kind of spaces would you enjoy? Please tick the boxes of your choice.

1    1    1,3,4,5,6,7,8    1,2,3,4,9    2,8

D. Aesthetics - What do you like your outdoor space to look and feel like? Colors, materials, textures? Please tick the boxes of your choice.

1,4,6    1,2,3,4,6,7,8,9    1,3,4,5,7,8    1

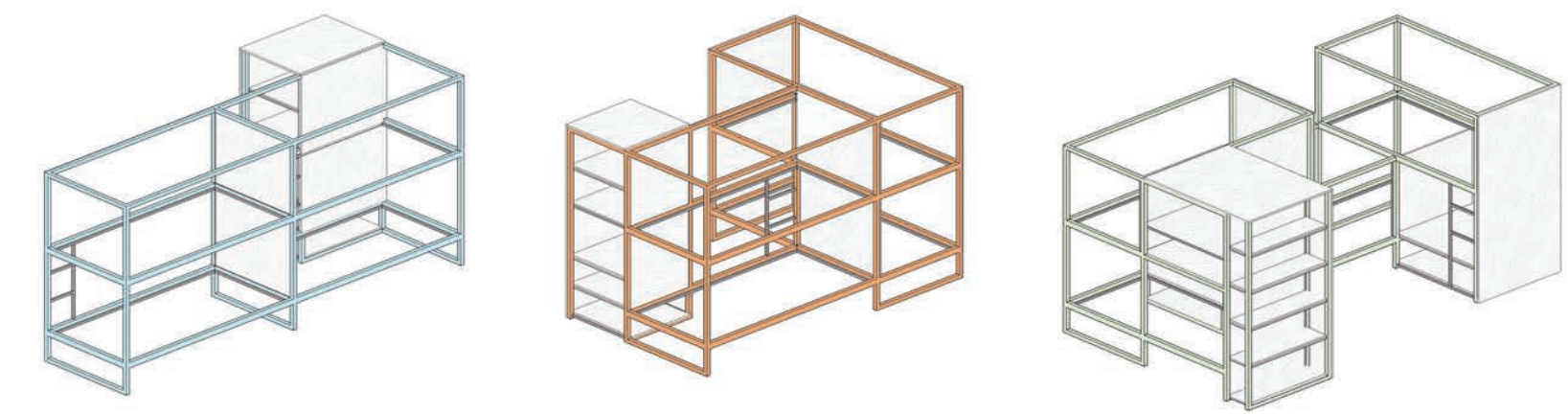

## PARTICIPATORY PROCESS

### COLLECTIVE VISIONING

ASA invited students to submit a questionnaire on their functional and aesthetic preferences for each of the spaces in the brief. Where there was a clear majority or consensus amongst students, the designers were able to draw on this information to influence the design.

For instance, the desire to do sporting activities in the common spaces lead to the inclusion of a climbing wall, while preferences over the form and quantity of bunk beds resulted in a bespoke inbuilt furniture system.

### PARTICIPATION TACTICS

Students were consulted throughout the process. The architects provided them with physical models of the design to engage and play with in order to gain their feedback.

### CAPACITY BUILDING

The design purposefully utilises locally available and affordable materials in order to engage the local community in the construction process, increasing job opportunities and improving ability to self-construct.



## SUSTAINABLE MATERIALS

### EARTHEN FLOOR

The RLS Dormitory has a cement-free earthen floor, developed by Earth Enable, which is made from different layers of compressed natural material. The first layer is compacted gravel, followed by coarse laterite, and a finely sieved sand and clay mix, which is burnished to form a beautifully smooth top layer. The floor is then sealed with linen oil, which permeates the fine earthen mix and forms a waterproof and plastic-like resin on top. This layer gives the floor its shine and makes it easy to clean and incredibly durable. Earth Enable predicts that in the East African climate earthen floors should last 10-15 years if maintained with a fresh coat of oil every 3 years.

### FIRED BRICK WALLS

Walls are constructed from locally fired bricks that are produced by local artisans with clay sourced from the nearby valley. The walls contain vertical reinforcement bars to improve stability and avoid the use of concrete.

### BAMBOO SCREENING

Bamboo is woven through metal burglar bars on the windows to give a softer and more natural aesthetic.

### RIVER CANE CEILING

River canes are lashed together to form a suspended ceiling in the bedrooms, which improves aesthetics, quality of light and thermal resistance from solar radiation.

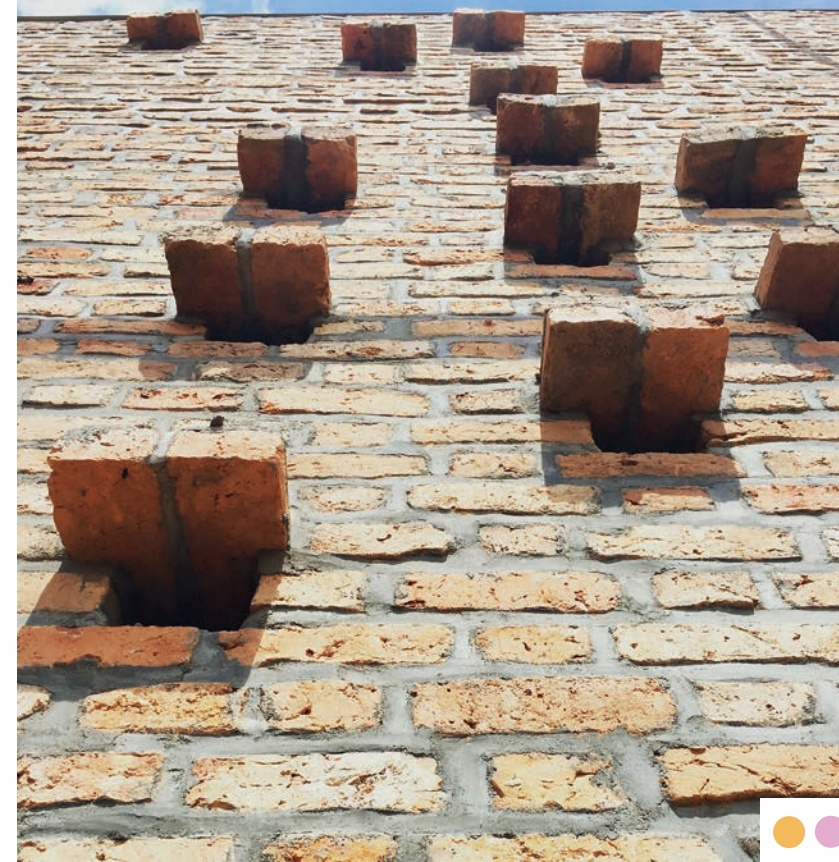

## PASSIVE VENTILATION

### OPENINGS

ASA often implement perforations in their brickwork for both aesthetic impact and to improve the thermal performance of their buildings through passive ventilation and night flushing. In the RLS Dormitory, they have developed rainproof perforations, where a protruding brick on the exterior helps to stop driving rain from penetrating into the building.

### CROSS VENTILATION

To mitigate the heating effect of the metal roof sheets, the building has been designed with an open clerestory to allow unrestricted airflow, encouraging passive cross ventilation.

## NATURAL DAYLIGHT

### EVEN DISTRIBUTION

Each bed space in each of the dormitory rooms is equipped with its own glass block window, while diffuse light from high level windows permeates into the space through the suspended river cane ceiling.



# QAWF PRIMARY SCHOOLS

Location	Geremech and Sarachom, Karamoja, Uganda
Architect	Studio FH Architects
Client	African Wildlife Foundation
Consultant	The Landscape Studio (Landscape) Aquila Gallery (Structural Engineers) Equatorsun (Services & AT Engineers) Dudley Kadibante and Partners (QS)
Size	2000sqm
Cost	\$380/sqm (excl. VAT)
Year	2018

These two primary schools, designed by Studio FH, are located in immediate adjacency to Kidepo Valley National Park in Karamoja, and form part of the African Conservation Schools Initiative by the African Wildlife Foundation. The programme, which commenced with Ilima Primary School (see page 75) provides incentives to the local population to embrace wildlife and learn to see it as an opportunity rather than a threat to their livelihoods.

Due to the remoteness of both sites and the associated high transport costs, building materials have been carefully selected that can be sourced locally. The Kidepo area has beautiful local stone which is utilised for foundations and plinth walls. Compressed earth blocks form the upper part of the walls. Sliding and top-hung steel panels made of woven strips of metal sheets form windows and doors, and provide both security and shading from the sun. An unusual amount of care has been given to the landscape design which is seen by the Client as key towards fostering a better relationship between the locals and their environment. Existing trees are being protected, local species added and innovative forms of appropriate agriculture introduced as demonstration farms and gardens.



## GENERAL ARRANGEMENT

The AWF Primary Schools both consist of a classroom block, external assembly space, kindergarten, staff accommodation, kitchen and toilet block. Each of the schools has been conceptualised with a different aesthetic character based on the unique environment in which it is located.

Geremeh, the Savannah School, is laid out much like a local village. Buildings are spread out in response to existing vegetation and create distinct external spaces between them. The buildings are aligned in east-west direction, both reducing site excavation works and the direct ingress of morning and evening sun.

Sarachom, the Farm School, takes its concept design from its agricultural surroundings. Distinct rectangular shapes with well-defined uses and subtle terracing turn this school into a 'demonstration farm' of sorts. Due to existing classrooms on site, new buildings have been located with a slightly less ideal orientation of 30° off the east-west axis. This is addressed by the use of small windows on the eastern fronts and very large roof overhangs on all western façades.

## SUSTAINABLE LANDSCAPE

The landscape design uses productive species in order to solve key issues, such as shelter from the wind, shade and food production for the school. The design also provides simple spaces for the children to learn and enjoy the outdoors.

### OFFSETTING

The planting plan employs native species already found on site in dramatic and yet simple ways to accentuate their features and maximise benefit to the environment. The indigenous Ficus for instance, is a keystone species that has a disproportionately large effect on the health and abundance of the local ecosystem, while also acting as key shade tree within the landscape design.

### PRODUCTIVITY

Each of the schools uses citrus trees to produce fruit for the children and as well as acting as a buffer zone between the school and its natural surroundings. Various medicinal plants grown on site are used to teach children the value of the local flora and fauna.

### ACTIVE LEARNING

There are moments where school and garden 'overlap' and the boundaries between inside and outside, classroom and playground become blurred. This encourages different forms of unconventional outdoor teaching and playful learning.



Bauhinia Petersiana



Citrus



Combretum Molle



Ficus Thoningii



Kigalia Africana



Mangifera Indica



Carica Papaya



Psidium Guajava



Tamarind Indica

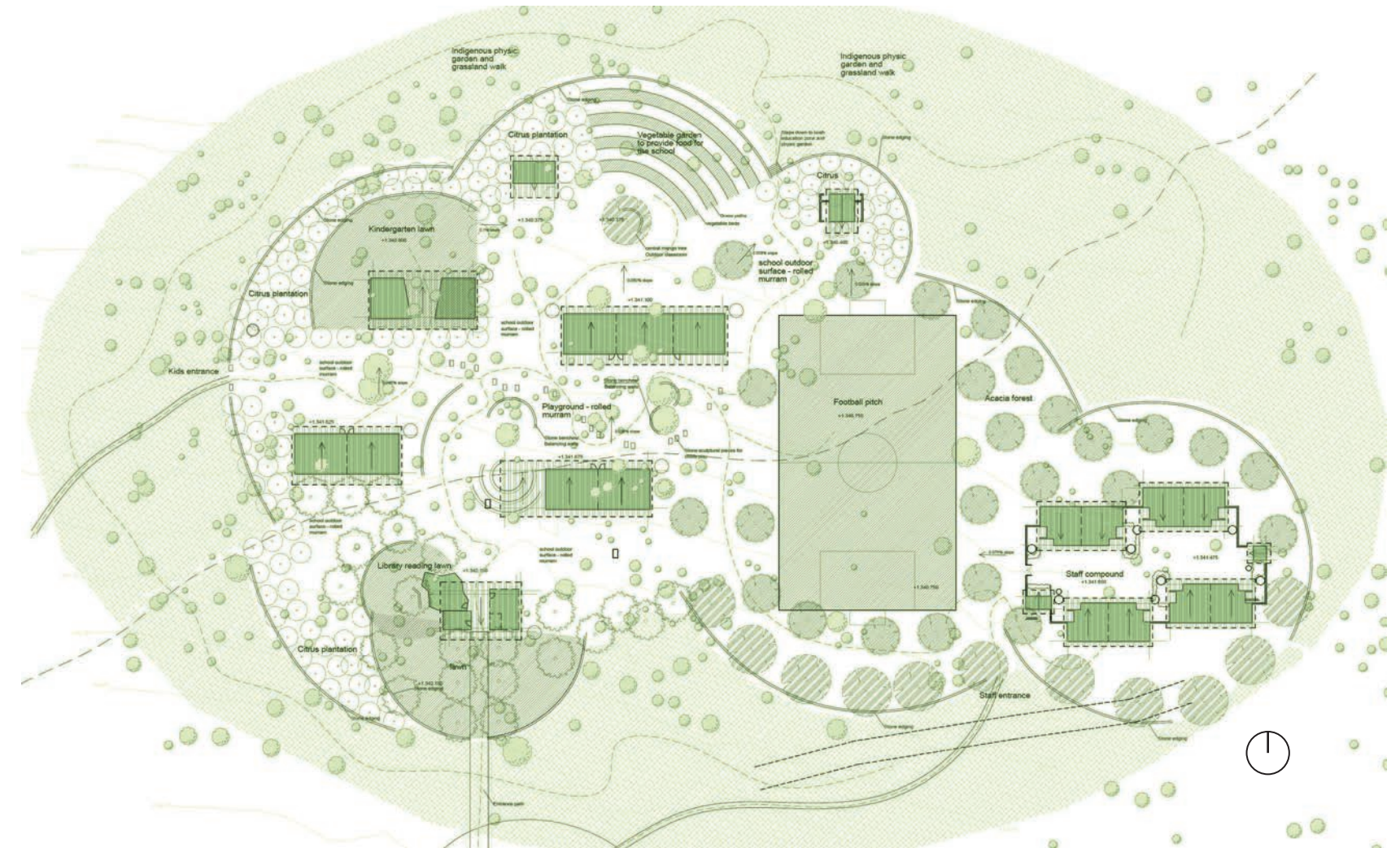



## SUSTAINABLE MATERIAL

Wherever possible, building materials are left natural; smooth concrete for floors and lintels, stone and compressed earth blocks for the walls, steel and bamboo for the roofs.

### STONE FOUNDATIONS

The schools are built on traditional rubble stone foundations - without the use of concrete - followed by semi-dry stack plinth walls made from granite blocks hand-mined from the site and compressed earth block walls above. This not only represents a near-carbon-free wall build-up but also a form of 'camouflage architecture' with the buildings harmoniously blending into their surroundings.

### CSEB WALLS

The compressed earth walls are made from non-interlocking 220mm stabilised earth blocks, comprised of a mix of cement, sand and soil in a ratio of 1:4:8. The square blocks are laid in mortar mixed in a similar ratio to the blocks themselves. Instead of a typical concrete ringbeam, the buildings each have a reinforced masonry ring beam composed of compressed earth 'trough blocks' with a reinforced concrete infill. The result is a near-monolithic wall, made entirely on site by masons trained in conventional concrete blockwork masonry.

### METAL SCREENING

As a reinterpretation of local craftsmanship, doors, windows and entrance canopies are made of coloured metal strips that are 'woven' around circular steel bars. This represents a colourful, creative and maintenance-free alternative to glass, providing weather protection and night-time security.

Property	Compressed Stabilised Earth Blocks	Fired Clay Bricks	Concrete Blocks
Wet Compressive Strength (MN/m <sup>2</sup> )	1 - 40	1 - 60	2 - 70
Moisture Movement (%)	0.02 - 0.2	0.00 - 0.02	0.02 - 0.10
Density (kg/m <sup>3</sup> )	1700 - 2200	1600 - 2100	600 - 2200
Thermal Conductivity (W/m·C)	0.81 - 1.04	0.70 - 1.30	0.15 - 1.7
Durability against rain	Good to very poor	Excellent to very poor	Good to poor



## NATURAL DAYLIGHT

### DISTRIBUTION AND CONTROL

The north façades of the classrooms have large window openings to connect the interior spaces with the environment. The windows are shaded by an external canopy, and are to be kept open except for during rainstorms or strong winds when they can be closed via a steel roller shutter. The south façades are much more enclosed with only small windows at randomised size, spacing and height; these windows can be closed via top-hung shutters which also act as sun shading.

### ROOFLIGHTING

The classroom has a thin strip of translucent roofsheet hidden in the ceiling above, which permanently illuminates the blackboard with daylight. In the library light-tubes protrude through the flat roof to transmit small amounts of coloured daylight into the centre of the space.

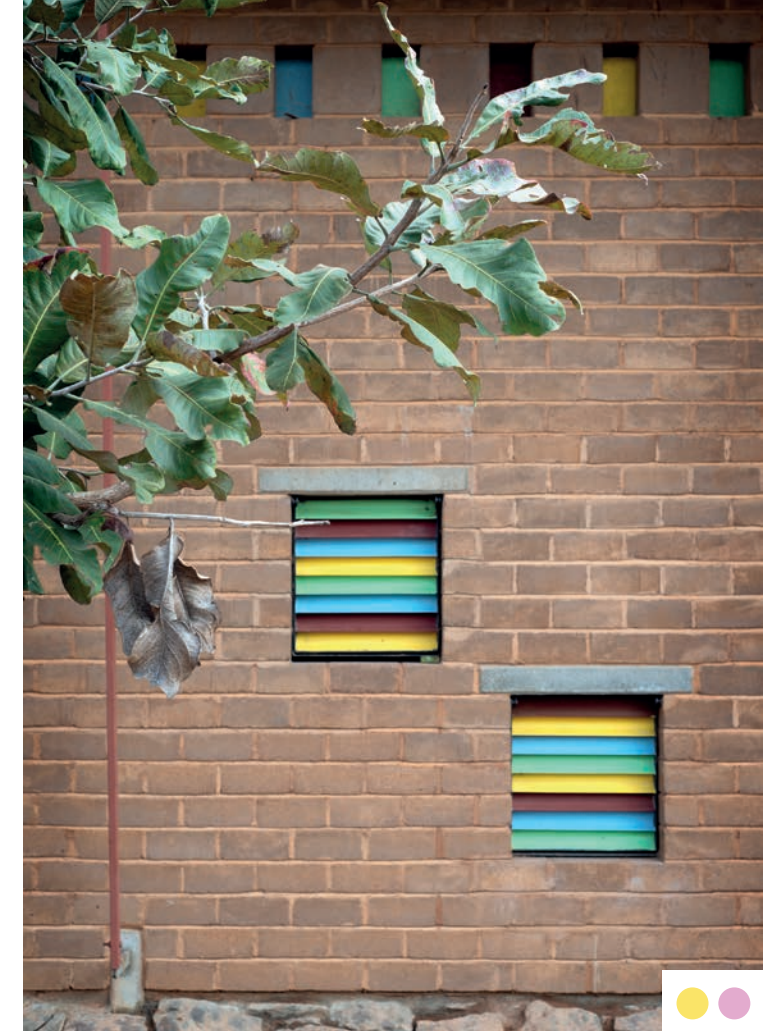
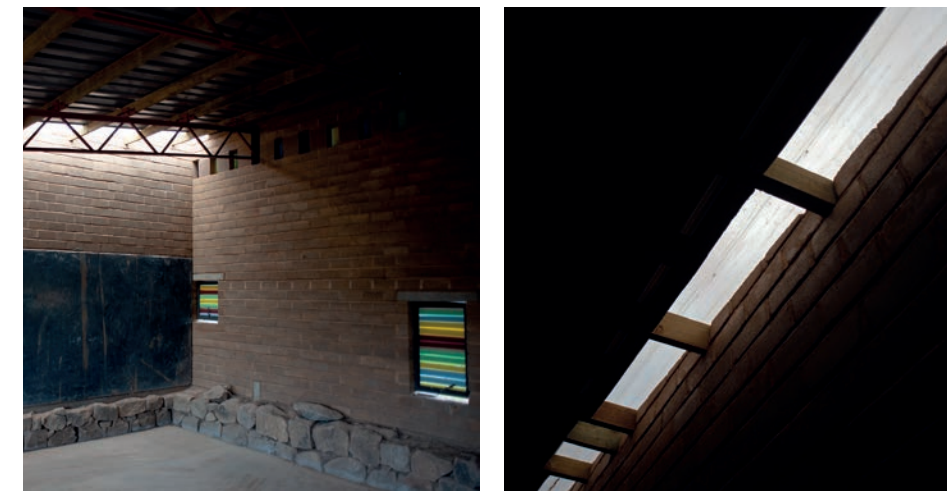
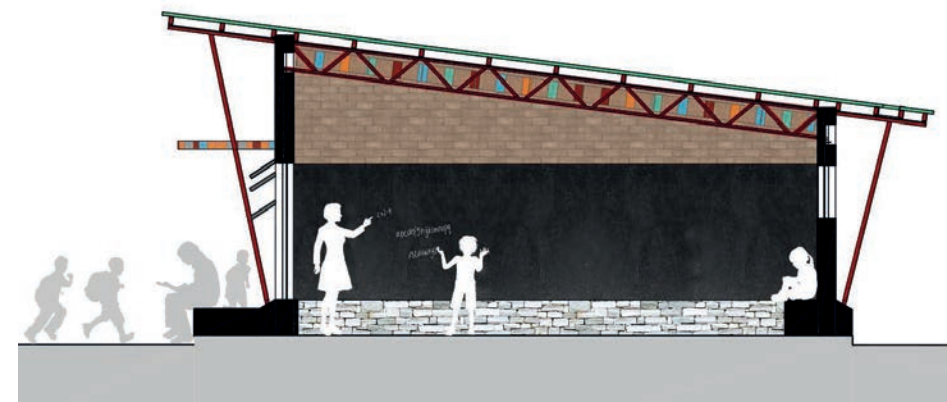

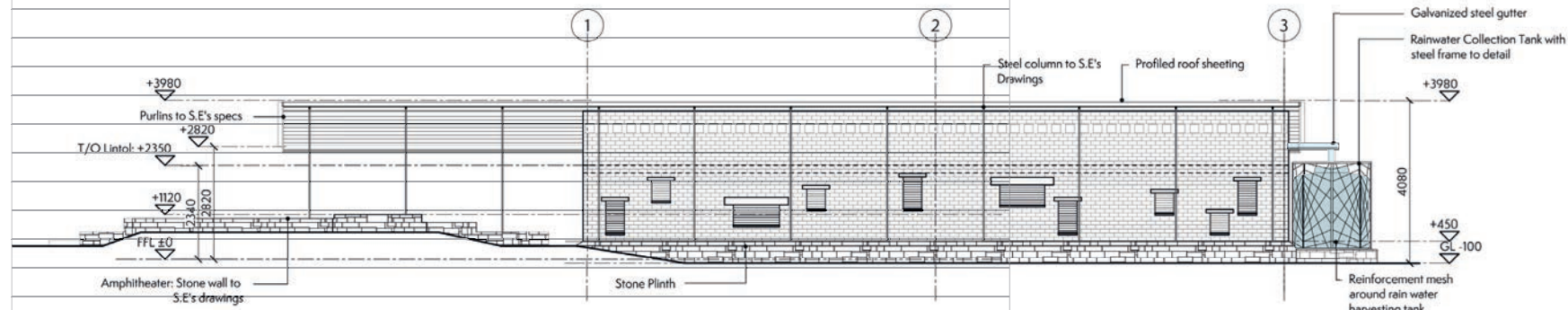
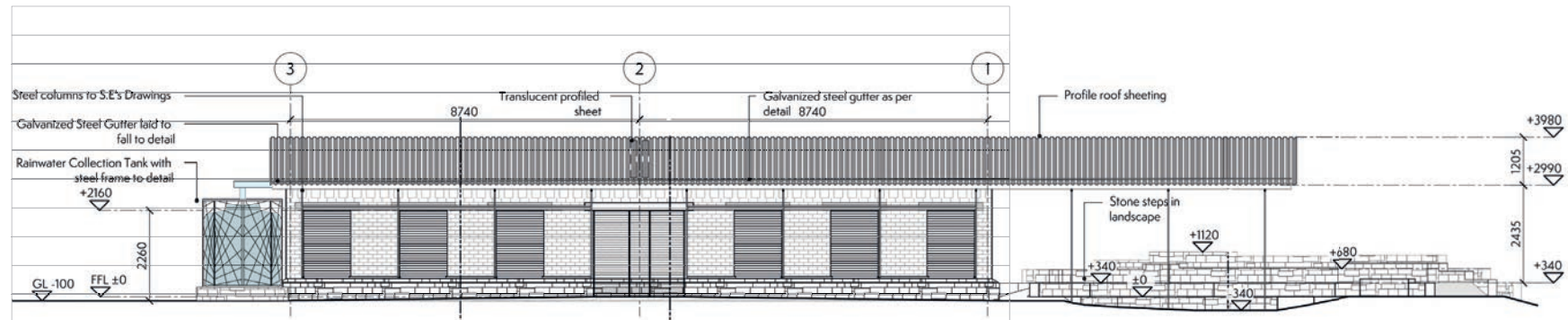

## WATER MANAGEMENT

### WATER SUPPLY

Eight 2,500L plastic tanks are located around the sites for optimum rainwater harvesting. The tanks are located at the same level and interconnected via underground pipes so that they function as one big tank. This system is adequate to meet the schools' water requirements for 8 months of the year, with a borehole available for use during dry spells.

### PLASTIC TANK SCREENING

The tanks are encased in a steel trellis, which allows creepers to grow and turn them into 'greened-up cylinders'. The creepers visually screen the plastic tanks from sight and protect them from potential UV damage.

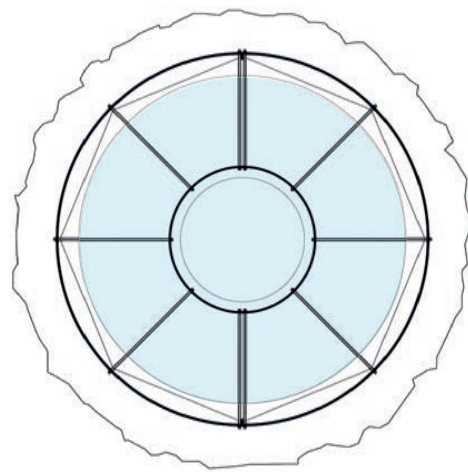
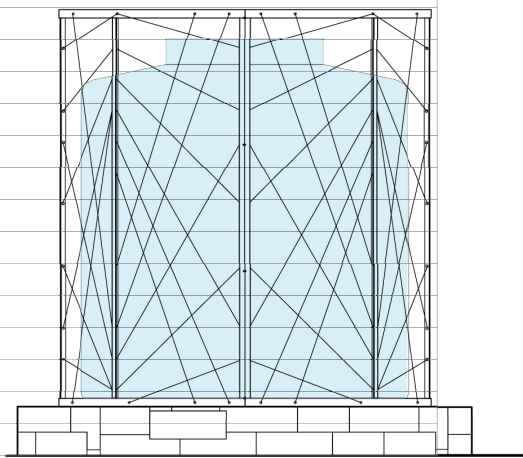

## ENERGY GENERATION

The off-grid schools require energy for various purposes such as cooking, water heating, lighting, wireless routers, computers and tablets.

### SOLAR PV

Solar panels are located on the roofs of the teachers' accommodation with a dedicated power room that stores the inverter, batteries and wireless router. The schools use battery water self-refilling systems to prolong the life of the batteries, which are expensive to replace.

### WIRELESS ROUTER

The wireless 'BRCK' system is comprised of a rugged portable router with a 3G data-enabled SIM card, which broadcasts a WiFi signal that can be shared with over twenty users. This system allows the AWF Primary Schools to remotely add educational material to the curriculum.

### BIOGAS

Hybrid ecostoves are fueled with biogas from an on-site bio-latrine system. The cooking gas is dispensed through a locally-made cast iron hob.



# 10 MZUZU UNIVERSITY HEALTH CENTRE

Location	Mzuzu, Malawi
Architect	Feilden Foundation (FCBStudios)
Client	Mzuzu University
Consultant	Happold Trust (Buro Happold Engineers) Max Fordham LLP (Environment Engineer)
Size	110sqm (Phase 1) 70sqm (Phase 2)
Cost	£15000 (Phase 1) \$27000 \$245/sqm £20000 (Phase 2) \$30000 \$430/sqm
Year	2005/2015

The Aids and Malaria treatment centre at Mzuzu University in Malawi was designed by Feilden Foundation volunteer architects, in a two-phase project that commenced in 2004. While the initial brief specifically called for a new health clinic, the wider objective of the project was to design and prototype an affordable alternative to the university's usual practice of importing expensive and environmentally inappropriate prefabricated buildings. The architects' aim therefore, was to provide the university with their own modular self-build system, which would utilise locally sourced and sustainably produced materials, and more significantly employ and develop the skills of local people.

Phase 2 of the project was instigated 10 years later to relieve pressure from the existing clinic, allowing it to house a larger and more welcoming entrance and administration building. The new building adapts and enhances the 'kit of parts' construction system developed during Phase 1. Both simple micro-budget buildings provide an environmentally sensitive approach to design, utilising various passive design principles while minimising the use of cement and hardwoods.







## SOLAR SHADING

### ORIENTATION

The precise position of the buildings was carefully calculated to keep the clinic as cool as possible. Each of the buildings, including the future Phase 3 ward, are orientated on the east-west axis with openings predominantly to the north and south. The buildings are offset from one another to ensure free-flowing movement of air.

### TREES & PLANTING

Efforts have been made to retain existing trees wherever possible in order to maximise shading of the east and west elevations. Where trees have had to be removed to facilitate construction, new ones have been planted in their place.

### ROOF COLOURING

The health clinic uses 10.7m lengths of shiny galvanised 'alu-zinc' roofing sheets to reflect solar radiation, helping to reduce radiant heat transfer to the interior spaces. Due to the low mono-pitch roof design the roofing material is barely visible, eliminating potential aesthetic concerns.

### DOUBLE ROOF

The modular cassette design means that the roof has an inbuilt ceiling and ventilated air space, which helps to keep the building cool as well as concealing plumbing and electrics. Phase 2 enhances the double roof shading effect by incorporating foil sisilation into the cassette design. This reflective foil lining further blocks radiant heat from penetrating into the spaces below.

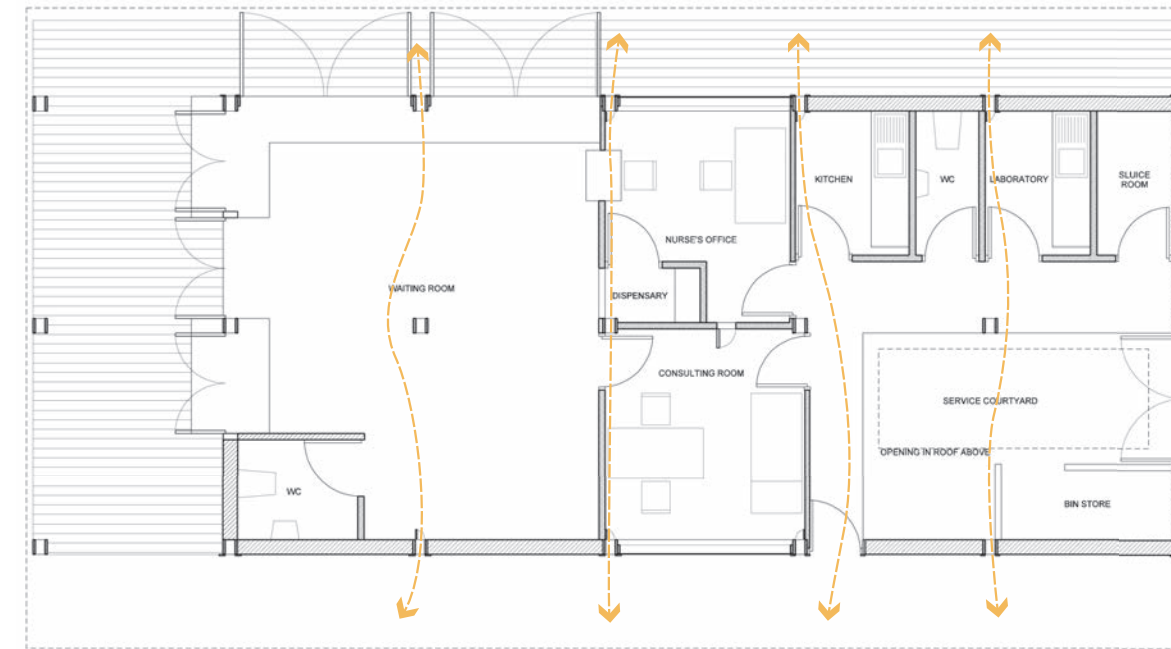

## PASSIVE VENTILATION

### OPENINGS

The initial column design of the Phase 1 clinic incorporated ventilation slots within the structure, which in theory eliminated the need for opening windows within the blockwork walls. On reflection, this strategy was found to be inefficient and overcomplicated to construct. The Phase 2 column design was simplified to become a solid unit, with ventilation being provided via mechanical glazed louvres.



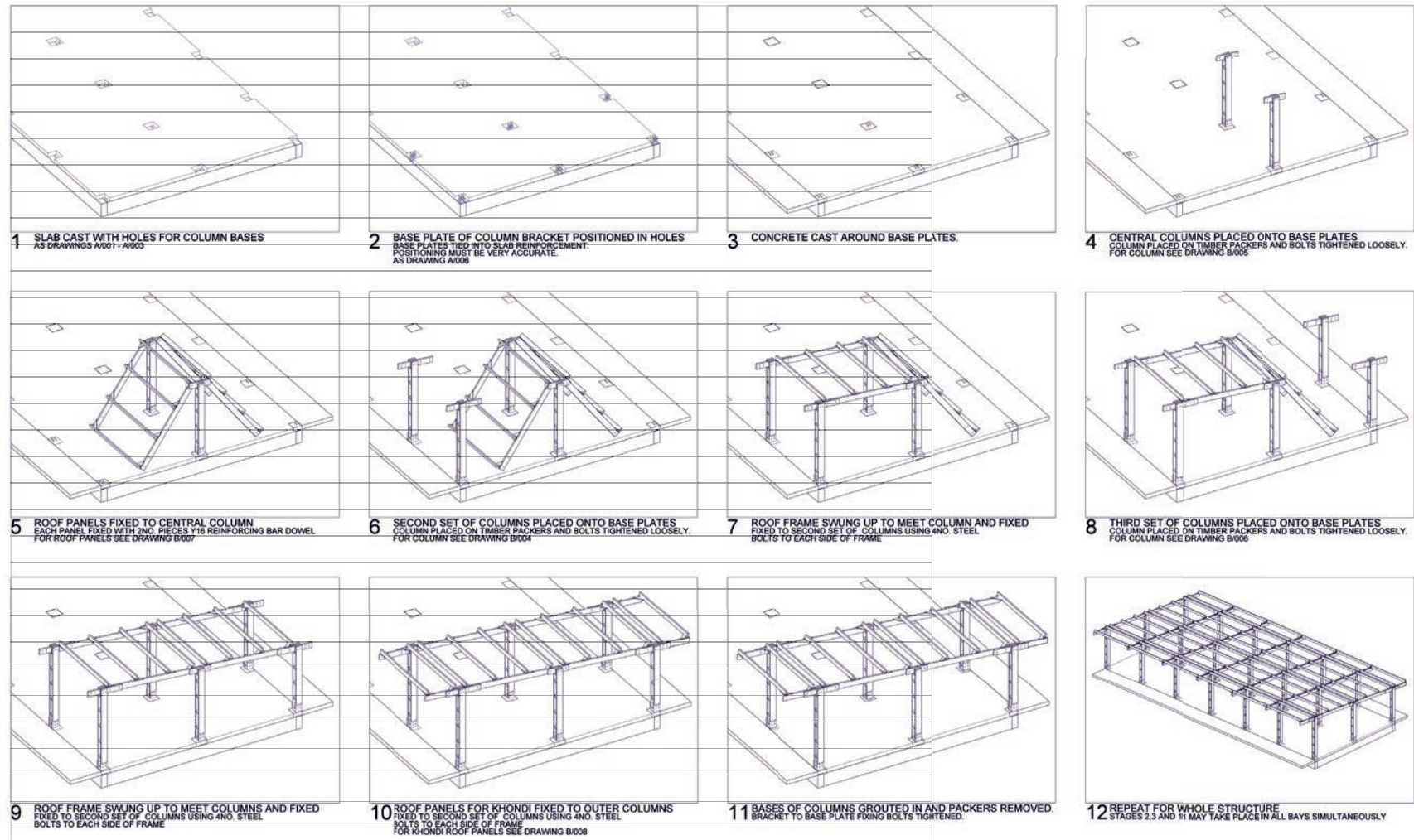

## PARTICIPATORY PROCESS

### MODULAR SYSTEMS

The primary focus of the project was to develop and prototype a highly affordable DIY construction system that could be handed over to the university to develop and replicate during their planned expansion. The concept was to create a 'kit of parts' that could be efficiently fabricated and erected by a small team of craftsmen without the need for cranes or scaffolding.

The system is comprised of a modular timber frame with an infill of stabilised soil blocks. A series of timber cassettes based on plywood sheet modules initially prop the frame before being manually lifted into place to form the roof. The system can be used in a number of configurations depending on the university's specific needs - classrooms, hostels or treatment wards.

### RESEARCH BY DESIGN

A considerable amount of research was undertaken to decide on an optimum soil mix for the stabilised soil blocks, which combined a unique colour balance with a suitable brick strength. The bricks were tested for their density and compressive strength at the Ministry of Works in Mzuzu. The final mix was comprised of soil, sand and cement at a ratio of 5:1:1

### POST-OCCUPANCY ANALYSIS

The architects used a small temperature measuring device called a Tinytag to assess the performance of the Phase 1 clinic, in order to inform the thermal mass and ventilation strategies during Phase 2.

Tinytags were located both inside and outside of the building and set to take readings every 30mins during a 24 hour period. The readings showed that the building was successfully 'peak-logging', with the inside staying cooler than the highs experienced outside, with an average maximum temperature difference of 3.3°C. This pattern was repeated at night, but with the building staying approximately 2.3°C warmer than outside.

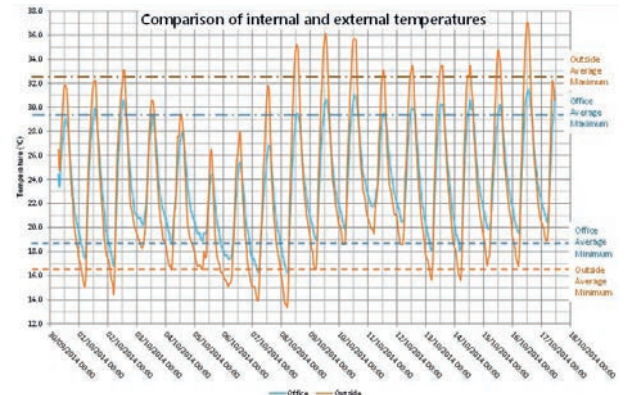

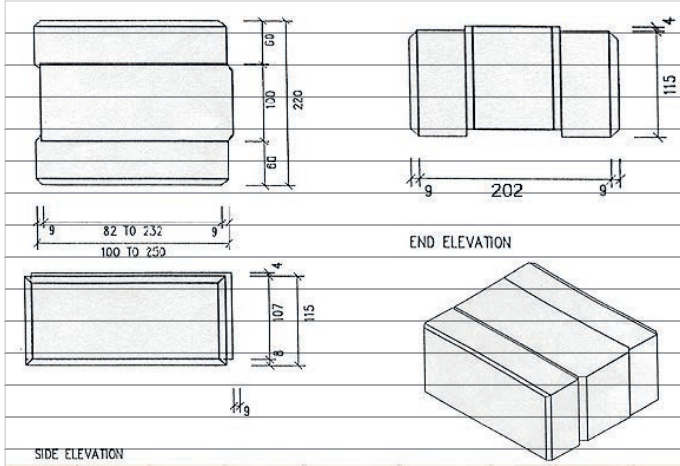

## SUSTAINABLE MATERIALS

The Mzuzu modular system provides a low carbon solution to building construction through avoiding the use of cement and hardwoods, focussing specifically on the innovation of a modular softwood frame and two-types of compressed earth blocks.

### TIMBER

The health centre adopts – rather unconventionally for Africa – a loadbearing timber frame structure. The softwood timber frame is handcrafted from locally and sustainably managed pine plantations, eliminating the need to transport large bulky components for thousands of miles to site.

### ISSB

Mzuzu Phase 1 uses interlocking soil blocks which were machine-made using an efficient hydraform press. The interlocking module allows the bricks to be laid dry without the need for cement mortar. Furthermore, Phase 1 predominantly uses locally produced lime as a binding agent instead of cement, although a cement stabiliser is used on blocks below 600mm due to its waterproofing properties and higher loading from the walls above. There is some trepidation around using lime as a replacement for cement, and this project proves that it is a viable alternative – Phase 1 was completed around 15 years ago and is happily still standing!

### CSEB

Mzuzu Phase 2 uses a non-interlocking soil block which allows for greater design flexibility but requires a 12mm cement mortar joint between courses. The blocks were manually pressed using a man-powered machine press, with a mix comprised of soil, sand and cement at a ratio of 5:1:1

### FIRED CLAY TILES

The flooring inside and immediately outside the health centre is inlaid with 7000 fired clay tiles, which were produced in a local pottery. The interior is characterised by square tiles, while the external spaces have rectangular tiles laid in a repetitive pattern. The tiles provide a hard wearing and attractive alternative to concrete flooring that can be easily mopped clean to keep the hospital environment sterile.



MZUZU PHASE 2 - CSEB



MAN-POWERED HAND PRESS



# 11 NAKAPIRIPIRIT VOCATIONAL INSTITUTE

Location	Nakapiripirit, Karamoja, Uganda
Architect	ProPlanPartners
Client	MoES Uganda / Enabel
Donor	Irish Aid
Size	504sqm
Cost	\$270,000 (\$535/sqm)
Year	2017-2019

Nakapiripirit Vocational Institute is a technical school focussed on agricultural and construction training. Prior to 2017 the school's facilities were dilapidated and disused, consisting of a few unfinished classrooms and dormitories with no water or electricity provision. The Ministry of Education and Enabel initiated a project to revitalise the institute's facilities and curriculum to give it greater relevance within the local community. The main objective was to empower and strengthen the community to enable them to develop and maintain their own school into the future.

Enabel consulted with teachers, administration, local authorities and students to develop a series of new activities in the form of student 'life projects' in landscaping and construction. The projects provide practical training, whilst also helping to manage the local ecosystem, rehabilitate any unusable buildings and provide new facilities as required by the institution. A new large multipurpose workshop has been constructed to provide a comfortable and conducive working environment for students to receive quality hands-on training. The workshop has been designed according to passive design principles and benefits from excellent natural daylighting and ventilation.



## GENERAL ARRANGEMENT

The heart of Nakapiripit Vocational Institute is a green courtyard at the centre of the masterplan, which provides the space for student landscape projects and acts as a showcase for the school's agricultural expertise. The courtyard is surrounded by classrooms and the dominant new workshop building. Other constructions, such as the new kitchen, BCP (brick laying and concrete practice) workshop and water and waste management facilities are scattered throughout the campus.

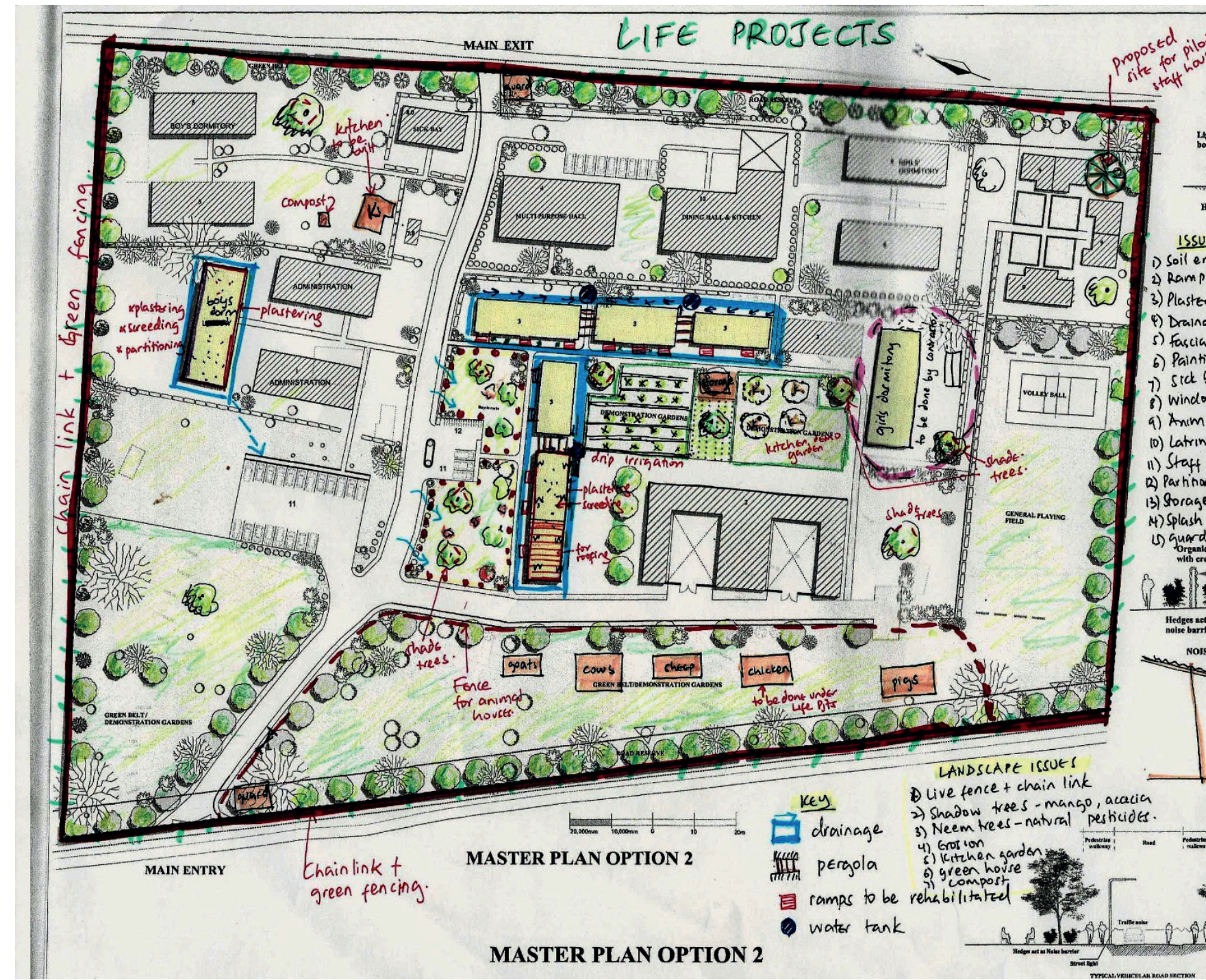
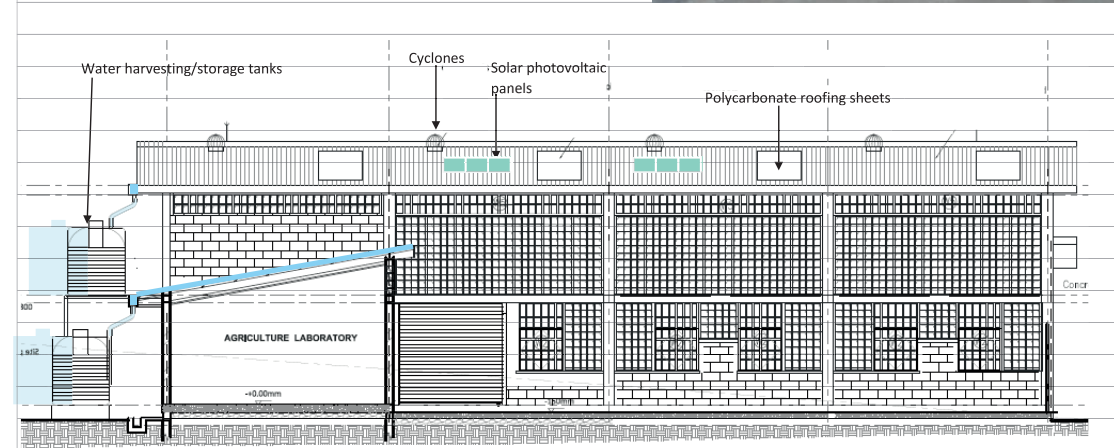

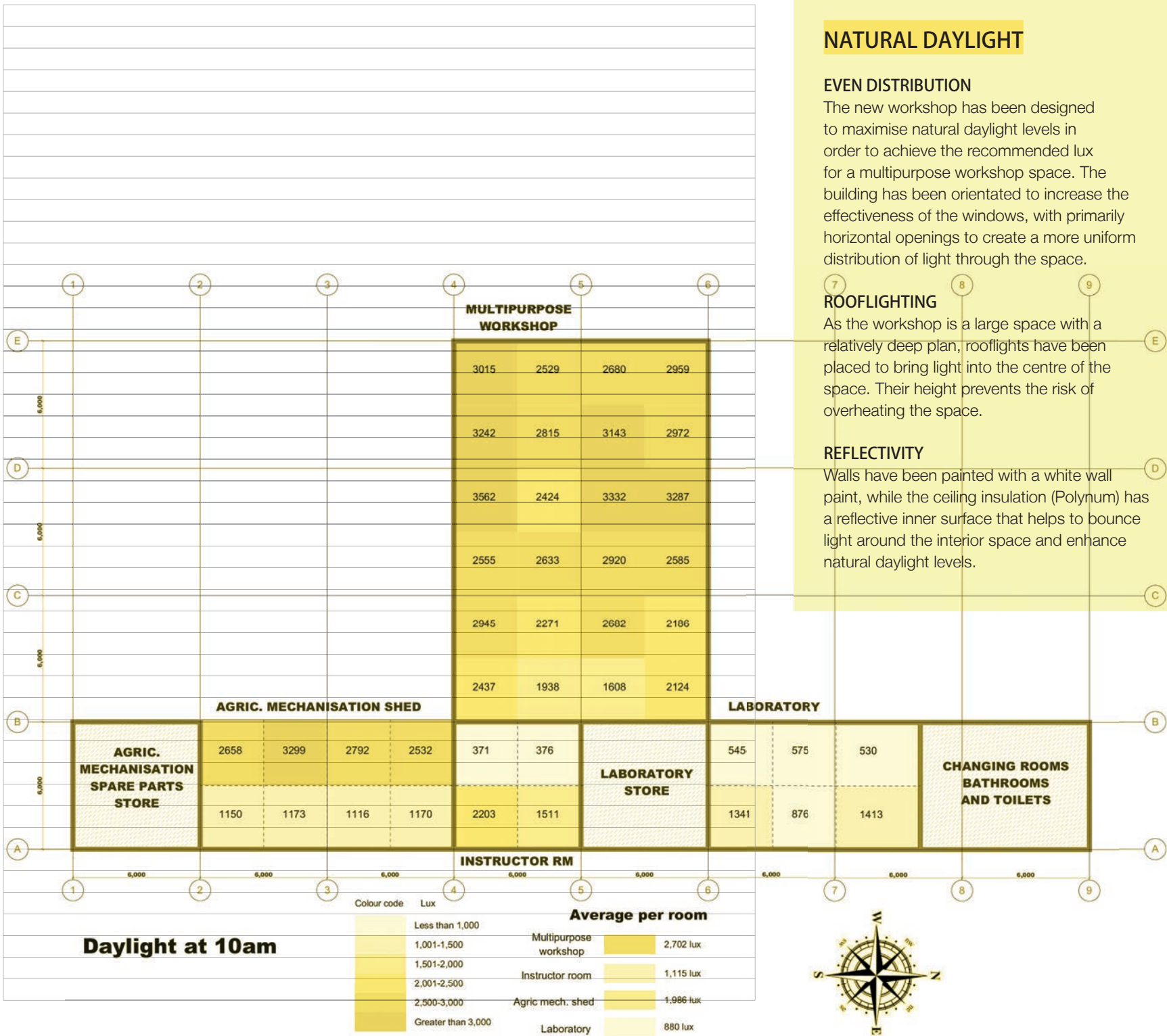

## NATURAL DAYLIGHT

### EVEN DISTRIBUTION

The new workshop has been designed to maximise natural daylight levels in order to achieve the recommended lux for a multipurpose workshop space. The building has been orientated to increase the effectiveness of the windows, with primarily horizontal openings to create a more uniform distribution of light through the space.

### ROOFLIGHTING

As the workshop is a large space with a relatively deep plan, rooflights have been placed to bring light into the centre of the space. Their height prevents the risk of overheating the space.

### REFLECTIVITY

Walls have been painted with a white wall paint, while the ceiling insulation (Polynum) has a reflective inner surface that helps to bounce light around the interior space and enhance natural daylight levels.

## PASSIVE VENTILATION

### OPENINGS

The walls of the workshop have been made extremely porous by designing a large surface area of permanent openings. This allows for continuous cross ventilation during the day, and for hot air and thermal build up to be flushed out during the night.

### MECHANICAL VENTILATION

Ventilation is further improved through the installation of 8 wind cyclones on the roof ridge that extract moisture and warm air from the building as required.

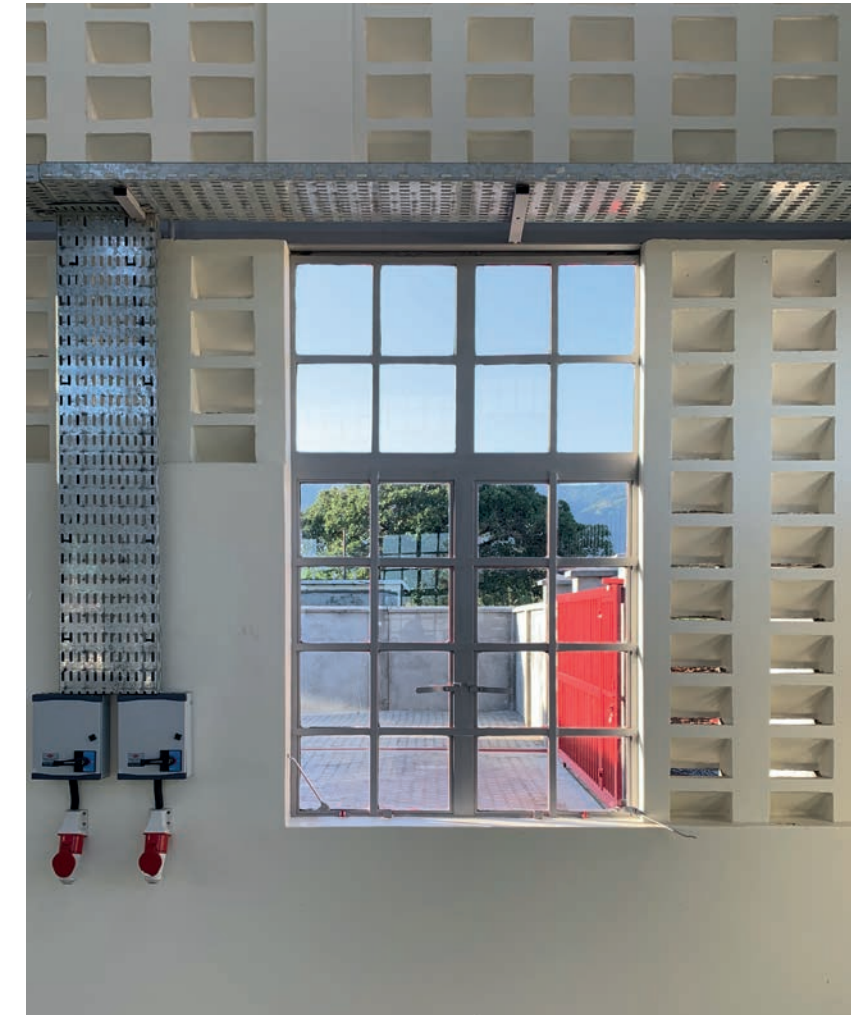

## WATER MANAGEMENT

### ISSB TANK

A 20,000L ISSB tank was constructed by students as part of a student life project in sustainable construction. The tank is made from a single wall of curved ISSB blocks, and stores rainwater from the existing building roofs.

### PLASTIC TANK

The new workshop is provided with four PVC water tanks to harvest water from the building. There are two 10,000L ground bearing tanks and two 5,000L elevated tanks. There is a further 16,000L elevated plastic water tank located near the kitchen, which is fed with water from a new solar powered borehole.



## ENERGY GENERATION

### SOLAR ENERGY

The new workshop is provided with photovoltaics panels to provide the minimum energy required to run the facilities - lights and a few computer specific plugs. Further solar panels have been located on the existing ICT building.

### SOLAR THERMAL

The kitchen is fitted with a solar water heater to preheat water, thereby reducing the quantity of firewood required for cooking purposes.



## SUSTAINABLE LANDSCAPE

### ACTIVE LEARNING

Student 'life projects' are a form of active learning at the core of the Nakapiripirit curriculum. Kitchen demonstration gardens and outdoor classrooms are the green heart of campus, providing interactive learning spaces within the natural landscape.

### REGENERATION

One student landscape activity is Farmer Managed Natural Regeneration (FMNR); a simple concept of systematically regenerating the natural environment using existing living tree stumps, roots or seedlings. The advantage is that roots are already well developed, ensuring high rates of success with low levels of financial investment. FMNR strengthens the local ecosystem through the propagation of native keystone species, resulting in increased soil fertility and improved pest control.

### PRODUCTIVITY

Native trees grown through FMNR may provide edible fruit, seeds and leaves, which nurture local wildlife and provide food, medicine and forest products for the school community.

### MITIGATION

Another student life project focuses on interventions to mitigate soil erosion, such as digging trenches, mulching and planting grasses.





A special word of thanks goes to Peter Clegg, Isabel Sandeman and Stephanie Sandall of Feilden Clegg Bradley Studios for the hard work and passion that they have put into this publication.

This publication is funded by Enabel as part of its education projects in Uganda.

We thank the Infrastructure Unit of Enabel in Kampala, Jan Van Lint and Mattias Piani, and the Construction Management Unit of the Ministry of Education, Eng. Doreen Matovu, who organized the Forum on 'Raising Awareness for Climate Responsive Design in East-Africa' on 27-28 February 2019.

We are very grateful to all speakers at the Forum for their active participation and who contributed with text and pictures to the different chapters of this document, more specifically:

Benoit Legrand	Enabel HQ, Belgium
Mark Olweny	Martyrs University, Uganda
Ben Haggard	Regenesis group, USA
Nadir Abdessemed	Transsolar KlimaEngineering, Germany
Josefien Vandermeulen	Enabel Uganda
Jean Paul Uzabakiriho	MASS Design Group, Rwanda
Agnes Ammeux	Enabel, Uganda
Mattias Piani	Enabel, Uganda
Felix Holland	FH Studio, Uganda
Peter Clegg	Feilden Clegg Bradley Studios, UK
Robert van Kats	Dasuda Foundation, The Netherlands
Mugdha Thakurdesai	Fielding Nair International, India
Francesco Stassi	ASA Studio, Rwanda
Alex Ndibwami	Kigali University, Rwanda
Edson Agume	Aquila Gallery



**Cover Image** © Nathan Ovens Feilden Foundation

**1** Cover image © Enabel

**7-8** © Nathan Ovens Feilden Foundation

**12** School Design © Transsolar

**12** Electricity Supply © Muhindo Walter

**12** Local Resource © MASS Design Group

**13** Temperature © Weatherspark

**13** Solar Radiation © Weatherspark

**14** Precipitation © Weatherspark

**14** Wind top - meteoblue. Climate (modelled) Kampala. URL

[https://www.meteoblue.com/en/weather/historyclimate/climatemodelled/kampala\\_uganda\\_232422](https://www.meteoblue.com/en/weather/historyclimate/climatemodelled/kampala_uganda_232422). Visited on 26.07.2019.

**14** Wind bottom © Weatherspark

**14** Comfort Conditions © Weatherspark

**15-16** © ASA Studio

**17** The Role of the Architect © Feilden Foundation

**17** Impact Design Methodology © MASS Design Group

**18** Immersion in Context © MASS Design Group

**18** Participation Tactics © ASA Studio

**18** Post Occupancy Analysis © Transsolar

**19** Local fabrication © MASS Design Group

**19** Capacity Building © MASS Design Group

**20** Research By Design © MASS Design Group

**20** Modular Systems © Feilden Foundation

**20** Empowerment © ASA Studio

**21-22** © Isabel Sandeman FCBStudios

**23** Environmental Impact both images © Will Boase Photography

**23** Embodied Energy © MASS Design Group

**24** Using local materials both images © MASS Design Group

**24** Avoiding waste © MASS Design Group

**24** Building typologies © Nathan Ovens Feilden Foundation

**25** Stone © Studio FH Architects

**25** Concrete both images © Nathan Ovens Feilden Foundation

**26** Limecrete - image sourced from pexels.com

**26** Earth top image © ASA Studio

**26** Earth bottom image © Earth Enable

**26** Tiles both images © MASS Design Group

**27** Fired bricks both images © Feilden Foundation

**27** Stabilised Earth © Hive Earth

**28** Stabilised Soil Blocks both images © Feilden Foundation

**28** Wattle and Daub top image © Isabel Sandeman FCBStudios

**28** Wattle and Daub bottom image - Living Tebago

**28** Stone both images © MASS Design Group

**29** Framing both images © ASA Studio

**29** Glazing © Feilden Foundation

**30** Screening both images © MASS Design Group

**30** Shutters © Nathan Ovens Feilden Foundation

**30** Insect Netting © Nadir Abdessemed

**31** Roof structure top image © ASA Studio

**31** Roof structure bottom image © Feilden Foundation

**31** Sheet material both images © Feilden Foundation

**32** Natural materials © MASS Design Group

**32** Fired Clay tiles both images © ASA Studio

**32** Ceilings © ASA Studio

**33** Engineered Timber both images © Nathan Ovens FCBStudios

**33** Light Earth Structures © Light Earth Designs LLP

**34** Strawboard both images © Strawtec

**34** Biocrete top image © BAM, Photo: Michael Danner

**34** Biocrete bottom image © Isabel Sandeman FCBStudios

**34** Recycled Materials © Will Boase Photography

**35-36** Chapter page image © ASA Studio

**37** Orientation sketch © FCBStudios

**37** Orientation image © FBW Group

**37** Overhangs sketch © FCBStudios

**37** Overhangs image © FBW Group

**38** Trees & planting sketch © FCBStudios

**38** Trees & planting image © MASS Design Group

**38** Roof colouring sketch © FCBStudios

**38** Roof colouring image © Will Boase Photography

**38** Double roof sketch © FCBStudios

**38** Double roof image © Erik-Jan Ouwerkerk

**39** Prevailing wind sketch © FCBStudios

**39** Prevailing wind image © Nadir Abdessemed

**39** Openings sketch © FCBStudios

**39** Openings image © Enabel

**40** Cross ventilation sketch © FCBStudios

**40** Cross ventilation image © Will Boase Photography

**40** Stack ventilation sketch © FCBStudios

**40** Stack ventilation image © Isabel Sandeman FCBStudios

**40** Night Cooling sketch © FCBStudios

**40** Night Cooling image © ASA Studio

**41** Even Distribution sketch © FCBStudios

**41** Even Distribution image © ASA Studio

**41** Daylight control sketch © FCBStudios

**41** Daylight control image © Feilden Foundation

**42** Rooflighting sketch © FCBStudios

**42** Rooflighting image © Will Boase Photography

**42** Reflectivity sketch © FCBStudios

**42** Reflectivity image © MASS Design Group

**42** Artificial lighting sketch © FCBStudios

**42** Artificial lighting image © FBW Group

**43** Offsetting & Regeneration © Feilden Foundation

**43** Productivity © ASA Studio

**44** Active learning © ASA Studio

**44** Climate cooling © Will Boase Photography

**44** Mitigation © Feilden Foundation

**45** Solar PV © Muhindo Walter

**45** Solar thermal © Muhindo Walter

**46** Firewood © Will Boase Photography

**46** Biogas top image © Studio FH Architects

**46** Biogas bottom image © Will Boase Photography

**46** Biofuel top image © Studio FH Architects

**46** Biofuel bottom image © Afri Banana Products

**47** Rainwater Harvesting sketch © FCBStudios

**47** Rainwater Harvesting image © Enabel

**47** First flush device sketch © FCBStudios

**47** First flush device image © Paul Kimera Feilden Foundation

**48** Borehole Water sketch © FCBStudios

**48** Borehole Water image © Voss Foundation / Good Future & Hope

**48** Filtering systems sketch © FCBStudios

**48** Filtering systems image © Paul Kimera Feilden Foundation

**48** Water, sanitation & hygiene sketch © FCBStudios

**48** Water, sanitation & hygiene image © ASA Studio

**49** Corrugated Iron © Paul Kimera Feilden Foundation

**49** Stainless Steel © FBW Group

**50** Plastic top image © FBW Group

**50** Plastic bottom image © Nathan Ovens Feilden Foundation

**50** Underground images © ASA Studio

**50** ISSB © MazziGo tanks

**51** The Waste Hierarchy © Isabel Sandeman FCBStudios

**51** Organic Waste top image © Enabel

**51** Organic Waste bottom image © Paul Kimera Feilden Foundation

**52** Hazardous Waste © Will Boase Photography

**52** Grey water Recycling © SuSanA Secretariat <https://www.flickr.com/photos/gtzeosan/6519920537/>

**52** Drainage © Feilden Foundation

**53** Ventilated Improved Pit Latrine sketch © FCBStudios

**53** Ventilated Improved Pit Latrine image © Feilden Foundation

**53** Ecosan toilet sketch © FCBStudios

**53** Ecosan toilet © ASA Studio

**54** Vermifilter Toilet sketch © FCBStudios

**54** Vermifilter Toilet image © Isabel Sandeman FCBStudios

**54** Bio-latrine sketch © FCBStudios

**54** Bio-latrine image © Studio FH Architects

**54** Water based system sketch © FCBStudios

**54** Water based system image © Paul Kimera Feilden Foundation

**55-56** © Feilden Foundation

**57-58** Intro Page © Will Boase Photography

**59** All images © Will Boase Photography

**60-62** All drawings © Studio FH Architects

**62-64** All images © Will Boase Photography

**64-65** All drawings © Studio FH Architects

**66** Top image © Studio FH Architects

**66** Drawing © Studio FH Architects

**66** Bottom image © Will Boase Photography

**67-74** All images and drawings © ASA Studio

**75-84** All images and drawings © MASS Design Group

**85-86** Intro page © Isabel Sandeman FCBStudios

**87** Left image © Enabel

**87** Top image © Nadir Abdessemed

**87** Middle image © Enabel

**87** Bottom image © FBW Group

**88-90** All drawings © FBW Group

**90** Bottom left image © FBW Group

**90** Bottom right image © Isabel Sandeman FCBStudios

**91** All drawings © FBW Group

**91** Right image © Isabel Sandeman FCBStudios

**91** Left image © FBW Group

**92** All images © Nadir Abdessemed

**93** All images and drawings © FBW Group

**94** Top left image © FBW Group

**94** Top right image © Isabel Sandeman FCBStudios

**94** Drawings © FBW Group

**95-96** Intro page © Feilden Foundation

**97** All images © Nathan Ovens Feilden Foundation

**98-101** All images and drawings © Feilden Foundation

**102** All images © Nathan Ovens Feilden Foundation

**103-104** All images © Feilden Foundation

**105-114** All images and drawings © ASA Studio

**115-116** Intro page image © Iwan Baan

**117** Drawings © MASS Design Group

**117** Top image © Volcanoes National Park

**117** Middle image © MASS Design Group

**117** Bottom image © MASS Design Group

**118** Drawing © MASS Design Group

**119-121** All images © MASS Design Group

**122** Top image © Iwan Baan

**122** Bottom left image © MASS Design Group

**122** Bottom middle image © MASS Design Group

**122** Bottom right image © MASS Design Group

**123** All images © MASS Design Group

**124** Top image © MASS Design Group

**124** Bottom image © Iwan Baan

**125-132** All images and drawings © ASA Studio

**133** Intro page image © Will Boase Photography

**135** Tree collage - Kigalia Africana © Bernard DUPONT / various unknown

**135** Right image © Will Boase Photography

**136** Drawing © Studio FH Architects

**136** All images © Will Boase Photography

**137** All images © Will Boase Photography

**138** Drawings © Studio FH Architects

**138** All images © Will Boase Photography

**139** All drawings © Studios FH Architects

**140** Top image © BRCK

**140** Middle image © Studio FH Architects

**140** Bottom image © Will Boase Photography

**141-145** All images and drawings © Feilden Foundation

**146** Left image © Feilden Foundation

**146** Middle and right image © Roberto Caputo FCBStudios

**146** Drawing © Feilden Foundation

**147** Drawings © Feilden Foundation

**147** Left image © Feilden Foundation

**147** Middle image © Roberto Caputo FCBStudios

**147** Right image © Roberto Caputo FCBStudios

**148-149** All images and drawings © Feilden Foundation

**150** Left image © Feilden Foundation

**150** Top image © Feilden Foundation

**150** Middle image © Roberto Caputo FCBStudios

**150** Bottom image © Feilden Foundation

**151-158** © Enabel

**160** © Nathan Ovens Feilden Foundation

© Feilden Clegg Bradley Studios, the authors.

All rights reserved. Reproduction in whole or part prohibited without prior permission.

Published by Feilden Clegg Bradley Studios

Bath Brewery

Toll Bridge Road

Bath BA1 7DE

All opinions expressed within this publication are those of the authors and not necessarily of the publisher.

Every effort has been made to trace the copyright holders, but if any have been inadvertently overlooked the necessary arrangements will be made at the first opportunity.

# A Manifesto for CLIMATE RESPONSIVE DESIGN

## FeildenCleggBradleyStudios

Feilden Clegg Bradley Studios  
Bath Brewery  
Toll Bridge Road  
Bath BA1 7DE  
UK  
t: +44(0)1225 852545  
fcbstudios.com



Enabel  
18 Lower Kololo Terrace  
P.O. Box 40131 - Kampala  
Uganda  
t: +256(0)414230543  
enabel.be



Enabel Headquarters  
Rue Haute 147-1000  
Brussels  
t: +3225053700  
info@enabel.be  
enabel.be